

Operating Systems and Networks

Assignment 7

1 Wireless Communication

Consider five wireless stations: A, B, C, D, and E. Station A can communicate with all other stations. B can communicate with A, C and E. C can communicate with A, B and D. D can communicate with A, C and E. E can communicate with A, D and B.

- a) When A is sending to B, what other communications are possible?
- b) When B is sending to A, what other communications are possible?
- c) When B is sending to C, what other communications are possible?

2 MACA

Six stations in a straight line, A through F, communicate using the Multiple Access with Collision Avoidance (MACA) protocol. Is it possible for two transmissions to take place simultaneously? Explain your answer.

3 CSMA/CA

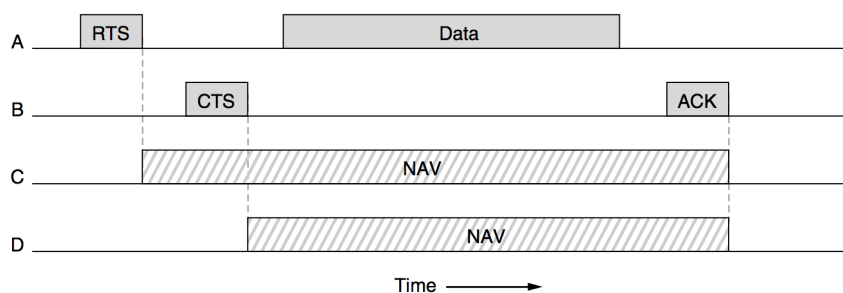

Figure 1: MACA

To reduce ambiguities about which station is sending, 802.11 defines channel sensing to consist of both *physical sensing* and *virtual sensing* (see Figure 1). Physical sensing simply checks the medium to see if there is a valid signal. With virtual sensing, each station keeps a logical record of when the channel is in use by tracking the NAV (Network Allocation Vector). Each frame carries a NAV field that says how long the sequence of which this frame is part will take to complete.

Which of the last two stations do you think is closest to A, and why?

4 CSMA/CD

If signal propagation speed in twin lead is $2.46 \cdot 10^8$ m/sec and signal propagation speed in multimode fiber is $1.95 \cdot 10^8$ m/sec,

- What is the length of a contention slot in CSMA/CD for a 2-km twin-lead cable?
- What is the length of a contention slot in CSMA/CD for a 40-km multimode fiber optic cable?

5 Spanning Tree Algorithm

- Given the network shown in Figure 2, where the letters A to J represent LANs and the circles B1 to B7 represent a switch node. Indicate which ports are not selected by the spanning tree algorithm.

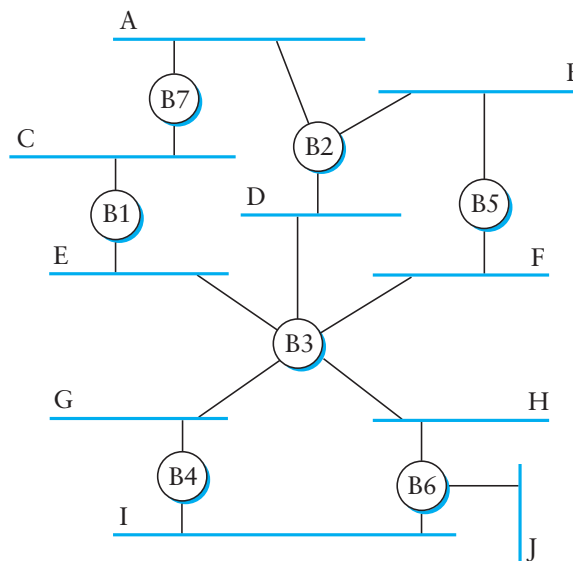

Figure 2: Network for spanning tree algorithm

- Given the network shown in Figure 2, assume that switch B1 suffers catastrophic failure. Indicate which ports are not selected by the spanning tree algorithm after the recovery process and a new tree has been formed.