

Operating Systems and Networks

Solution 7

Note: these solutions constitute material *supplemental* to the exercise sessions.

1 Wireless Communication

Consider five wireless stations: A, B, C, D, and E. Station A can communicate with all other stations. B can communicate with A, C and E. C can communicate with A, B and D. D can communicate with A, C and E. E can communicate with A, D and B.

- a) When A is sending to B, what other communications are possible?
- b) When B is sending to A, what other communications are possible?
- c) When B is sending to C, what other communications are possible?

Answer:

- a) Since all stations will see A's packet, it will interfere with receipt of any other packet by any other station. So, no other communication is possible in this case.
- b) Although B's packet will not be seen by D, other nodes cannot send to D because the packets from these nodes will interfere with the packets from B at A. Therefore, other communications is not possible at the same time.
- c) B's packet will be seen by E, A and C, but not by D. Thus, E can send to D at the same time.

2 MACA

Six stations in a straight line, A through F, communicate using the Multiple Access with Collision Avoidance (MACA) protocol. Is it possible for two transmissions to take place simultaneously? Explain your answer.

Answer: Yes. Since they are in a straight line and that each station can reach only its nearest neighbors, A can send to B while E is sending to F.

3 CSMA/CA

To reduce ambiguities about which station is sending, 802.11 defines channel sensing to consist of both *physical sensing* and *virtual sensing* (see Figure 1). Physical sensing simply checks the medium to see if

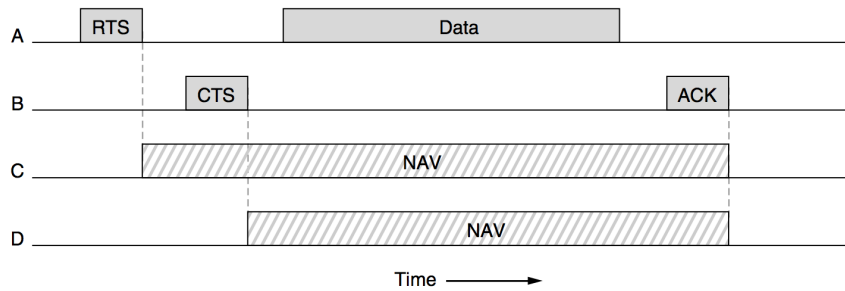

Figure 1: MACA

there is a valid signal. With virtual sensing, each station keeps a logical record of when the channel is in use by tracking the NAV (Network Allocation Vector). Each frame carries a NAV field that says how long the sequence of which this frame is part will take to complete.

Which of the last two stations do you think is closest to A, and why?

Answer: Station C is the closest to A since it heard the RTS and responded to it by asserting its NAV signal. D did not respond, so it must be outside A's radio range.

4 CSMA/CD

If signal propagation speed in twin lead is $2.46 \cdot 10^8$ m/sec and signal propagation speed in multimode fiber is $1.95 \cdot 10^8$ m/sec,

- What is the length of a contention slot in CSMA/CD for a 2-km twin-lead cable?
- What is the length of a contention slot in CSMA/CD for a 40-km multimode fiber optic cable?

Answer:

- Signal propagation speed in twin lead is $2.46 \cdot 10^8$ m/sec. Signal propagation time for 2 km is $8.13 \mu\text{sec}$. So, the length of contention slot is $16.26 \mu\text{sec}$.
- Signal propagation speed in multimode fiber is $1.95 \cdot 10^8$ m/s. Signal propagation time for 40 km is $205.13 \mu\text{sec}$. So, the length of contention slot is $410.26 \mu\text{sec}$.

5 Spanning Tree Algorithm

- Given the network shown in Figure 2, where the letters A to J represent LANs and the circles B1 to B7 represent a switch node. Indicate which ports are not selected by the spanning tree algorithm.
- Given the network shown in Figure 2, assume that switch B1 suffers catastrophic failure. Indicate which ports are not selected by the spanning tree algorithm after the recovery process and a new tree has been formed.

Answer:

We depict the collection of switches in a local area network (LAN) as a graph whose nodes are switches and LAN segments (or cables), and whose edges are the interfaces connecting the switches to the segments.

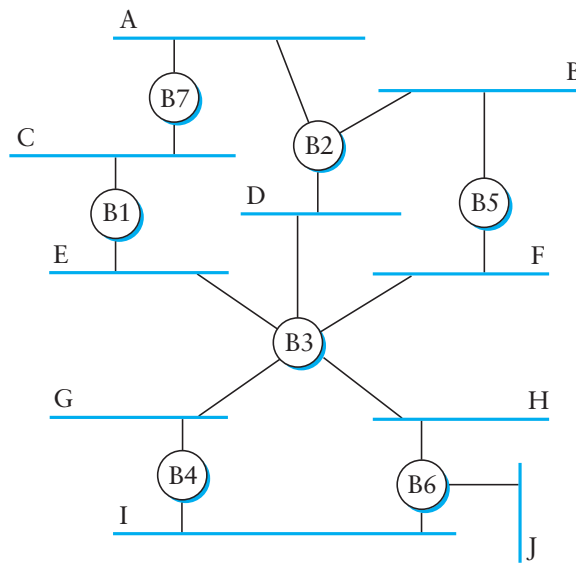

Figure 2: Network for spanning tree algorithm

The spanning tree algorithm works as follows ¹:

- Elect a single switch, among all the switches on all the LANs, to be the *Root Bridge*.
- Calculate the distance of the shortest path from the switches to the Root Bridge.
- For each LAN, elect *Designated Bridge* from among the switches residing on that LAN. The elected switch is the one closest to the Root Bridge. The Designated Bridge will forward packets from that LAN toward the Root Bridge.
- Choose a port (known as the *root port*) that gives the best path from each Designated Bridge to the Root Bridge.
- Select ports to be included in the spanning tree. The port selected will be the root port plus any ports on which 'self' has been elected Designated Bridge.

The ports which are not selected by the spanning tree algorithm are shown as red dotted lines in Figure 3.

After the recovery process, the new formed spanning tree is shown in Figure 4. The ports which are not selected by the spanning tree algorithm are shown as red dotted lines.

¹Radia Perlman. 1999. Interconnections (2nd Ed.): Bridges, Routers, Switches, and Internetworking Protocols. Addison-Wesley Longman Publishing Co., Inc., Boston, MA, USA.

