

ETH zürich spc1.inf.ethz.ch @spcl_eth

ADRIAN PERRIG & TORSTEN HOEFLER

Networks and Operating Systems (252-0062-00)

Chapter 2: Processes

IF SOMEONE STEALS MY LAPTOP WHILE I'M LOGGED IN, THEY CAN READ MY EMAIL, TAKE MY MONEY, AND IMPERSONATE ME TO MY FRIENDS, BUT AT LEAST THEY CAN'T INSTALL DRIVERS WITHOUT MY PERMISSION.
© source: xkcd.com

RSA Key Extraction via Low-Bandwidth Acoustic Cryptanalysis

Genkin, Shamir, Tromer, Dec. 2013

"Here, we describe a new acoustic cryptanalysis key extraction attack, applicable to GnuPG's current implementation of RSA. The attack can extract full 4096-bit RSA decryption keys from laptop computers (of various models), within an hour, using the sound generated by the computer during the decryption of some chosen ciphertexts."

<http://tau.ac.il/~tromer/acoustic/>

ETH zürich spc1.inf.ethz.ch @spcl_eth

Last time: introduction

- **Introduction: Why?** →
- **Roles of the OS**
 - Referee
 - Illusionist
 - Glue
- **Structure of an OS**

Setting the date to 1 January 1970 will brick your iPhone, iPad or iPod touch

February 12, 2016

Date bug will prevent 64-bit iOS devices from booting up, rendering them inoperable even through fail-safe restore methods using iTunes

Date bug bricks iPhones locking them in a boot loop if turned off. Photograph: Amy/MicrostockPhoto

Manually setting the date of your iPhone or iPad to 1 January 1970, or tricking your friends into doing it, will cause it to get permanently stuck while trying to boot back up if it's switched off.

The bug within Apple's date and time settings within iOS causes such an issue that users are reporting that the fail-safe restore techniques using iTunes are not able to repair the problem.

2

ETH zürich spc1.inf.ethz.ch @spcl_eth

This time

- Entering and exiting the kernel
- Process concepts and lifecycle
- Context switching
- Process creation
- Kernel threads
- Kernel architecture
- System calls in more detail
- User-space threads

3

ETH zürich spc1.inf.ethz.ch @spcl_eth

General OS structure

4

ETH zürich spc1.inf.ethz.ch @spcl_eth

Kernel

- **That part of the OS which runs in privileged mode**
 - Large part of Unix and Windows (except libraries)
 - Small part of L4, Barrelfish, etc. (microkernels)
 - Does not exist in some embedded systems
- **Also known as:**
 - Nucleus, nub, supervisor, ...

5

ETH zürich spc1.inf.ethz.ch @spcl_eth

The kernel is a program!

- **Kernel is just a (special) computer program.**
- **Typically an event-driven server.**
- **Responds to multiple entry points:**
 - System calls
 - Hardware interrupts
 - Program traps
- **May also include internal threads.**

6

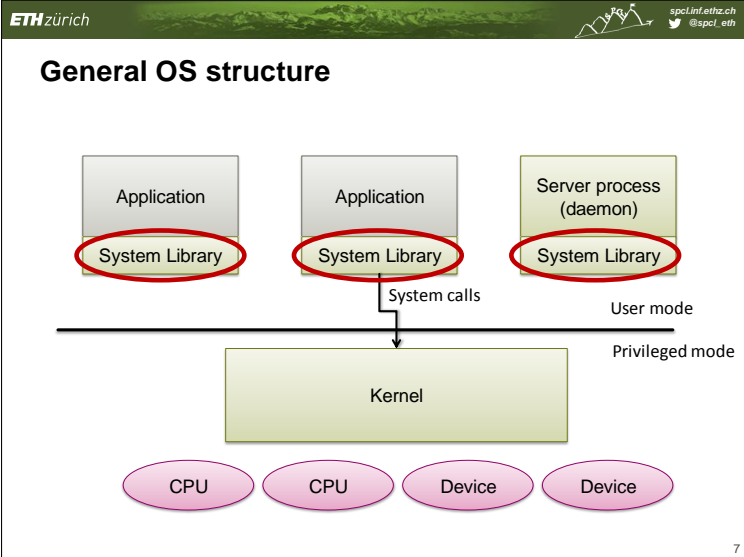

- ETH zürich spc1.inf.ethz.ch @spcl_eth
- ### System Libraries
- **Convenience functions**
 - printf(), etc.
 - Common functionality
 - **System call wrappers**
 - Create and execute system calls from high-level languages
 - See 'man syscalls' on Linux
- 8

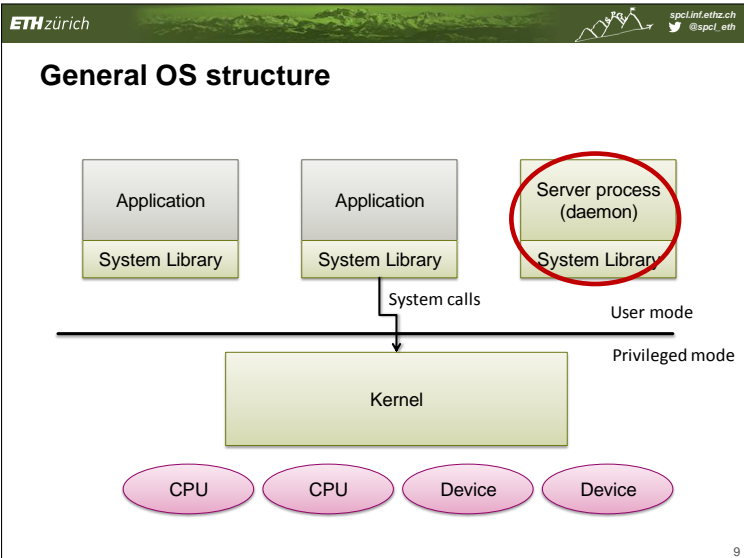

- ETH zürich spc1.inf.ethz.ch @spcl_eth
- ### Daemons
- **Processes which are part of the OS**
 - Microkernels: most of the OS
 - Linux: increasingly large quantity
 - **Advantages:**
 - Modularity, fault tolerance
 - Easier to *schedule*...
- 
- 10

ETH zürich spc1.inf.ethz.ch @spcl_eth

Entering and exiting the kernel

11

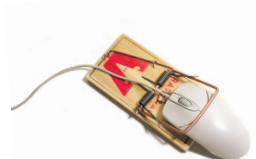
- ETH zürich spc1.inf.ethz.ch @spcl_eth
- ### When is the kernel entered?
- **System Startup and ...**
 - **Exception (aka. trap):** caused by user program
 - **Interrupt:** caused by "something else"
 - **System calls**
 - **Exception vs. Interrupt vs. System call** (analog technology quiz, raise hand)
 - Division by zero
 - Fork
 - Incoming network packet
 - Segmentation violation
 - Read
 - Keyboard input
- 
- 12

ETH zürich spci.inf.ethz.ch
@spci_eth

Recall: System Calls

- RPC to the kernel
- Kernel is a series of syscall event handlers
- Mechanism is hardware-dependent

```

    graph LR
      subgraph User_Mode [User mode]
        A[User process runs] --> B[Execute syscall]
        B --> D[Process resumes]
      end
      subgraph Privileged_Mode [Privileged mode]
        C[Execute kernel code]
      end
      B --> C
      C --> D
  
```

System calls 13

ETH zürich spci.inf.ethz.ch
@spci_eth

System call arguments

Syscalls are *the* way a program requests services from the kernel.

Implementation varies:

- Passed in processor registers
- Stored in memory (address (pointer) in register)
- Pushed on the stack

- System library (libc) wraps as a C function
- Kernel code wraps handler as C call

14

ETH zürich spci.inf.ethz.ch
@spci_eth

When is the kernel exited?

- **Creating a new process**
 - Including startup
- **Resuming a process after a trap**
 - Exception, interrupt or system call
- **User-level upcall**
 - Much like an interrupt, but to user-level
- **Switching to another process**

15

ETH zürich spci.inf.ethz.ch
@spci_eth

Processes

16

ETH zürich spci.inf.ethz.ch
@spci_eth

Process concept

“The execution of a program with restricted rights”

- **Virtual machine, of sorts**
- **On older systems:**
 - Single dedicated processor
 - Single address space
 - System calls for OS functions
- **In software:**
computer system = (kernel + processes)

17

ETH zürich spci.inf.ethz.ch
@spci_eth

Process ingredients

- **Virtual processor**
 - Address space
 - Registers
 - Instruction Pointer / Program Counter
- **Program text (object code)**
- **Program data (static, heap, stack)**
- **OS “stuff”:**
 - Open files, sockets, CPU share,
 - Security rights, etc.

18

ETH zürich spci.inf.ethz.ch @spci_eth

Process address space

Should look familiar ...

(addresses are examples: some machines used the top address bit to indicate kernel mode)

19

ETH zürich spci.inf.ethz.ch @spci_eth

Process lifecycle

20

ETH zürich spci.inf.ethz.ch @spci_eth

Multiplexing

- OS time-division multiplexes processes
 - Or space-division on multiprocessors
- Each process has a **Process Control Block (PCB)**
 - In-kernel data structure
 - Holds all virtual processor state
 - Identifier and/or name
 - Registers
 - Memory used, pointer to page table
 - Files and sockets open, etc.

21

ETH zürich spci.inf.ethz.ch @spci_eth

Process control block

22

ETH zürich spci.inf.ethz.ch @spci_eth

Process switching

23

ETH zürich spci.inf.ethz.ch @spci_eth

Process Creation

24

Process creation

- **Bootstrapping problem. Need:**
 - Code to run
 - Memory to run it in
 - Basic I/O set up (so you can talk to it)
 - Way to refer to the process
- Typically, “spawn” system call takes enough arguments to construct, from scratch, a new process.

Process creation on Windows

Did it work?

```

BOOL CreateProcess (
    in_opt LPCTSTR ApplicationName,
    inout_opt LPTSTR CommandLine,
    in_opt LPSECURITY_ATTRIBUTES ProcessAttributes,
    in_opt LPSECURITY_ATTRIBUTES ThreadAttributes,
    in BOOL InheritHandles,
    in DWORD CreationFlags,
    in_opt LPVOID Environment,
    in_opt LPCTSTR CurrentDirectory,
    in LPSTARTUPINFO StartupInfo,
    out LPPROCESS_INFORMATION ProcessInformation
);
    
```

What to run?

What rights will it have?

What will it see when it starts up?

The result

Moral: the parameter space is large!

Unix fork () and exec ()

Dramatically simplifies creating processes:

1. fork () : creates “child” copy of calling process
2. exec () : replaces text of calling process with a new program
3. There is no “CreateProcess (. . .)”.

Unix is entirely constructed as a family tree of such processes.

Unix as a process tree

PPID	PID	PGID	SID	TTY	TPGID	STAT	UID	TIME	COMMAND
0	1	1	1	?		-1 Ss	0	0:01	/sbin/init
1	437	436	436	?		-1 S	0	0:00	upstart-udev-bridge --daemon
1	439	439	439	?		-1 Ss	0	0:00	udevad --daemon
439	2065	439	439	?		-1 Ss	0	0:00	\. udevd --daemon
439	2086	439	439	?		-1 Ss	0	0:00	\. udevd --daemon
1	857	857	857	?		-1 Ss	0	0:00	dd bs=1 if=/proc/kmsg of=/var/run/rsyslog/k
1	864	859	859	?		-1 Sl	101	0:00	rsyslogd -n
1	675	675	675	?		-1 Ss	108	0:03	dbus-daemon --system --fork
729	745	745	745	?		-1 Ss	110	0:00	\. avahi-daemon: chroot helper
1	731	731	731	?		-1 Ss	111	0:02	halid --daemon
731	853	731	731	?		-1 S	0	0:00	\. hald-runner
853	1044	731	731	?		-1 S	0	0:00	\. /usr/lib/hal/hald-addon-efill-kill
853	1045	731	731	?		-1 S	0	0:00	\. /usr/lib/hal/hald-addon-leds
853	1060	731	731	?		-1 S	0	0:00	\. /usr/lib/hal/hald-addon-generic-bac
853	1074	731	731	?		-1 B	0	0:01	\. hald-addon-storage: polling /dev/sd
853	1065	731	731	?		-1 S	0	0:00	\. hald-addon-tpm: Listening on /dev
853	1100	731	731	?		-1 S	0	0:00	\. /usr/lib/hal/hald-addon-cpufreq
853	1101	731	731	?		-1 S	111	0:00	\. hald-addon-api: listening on apid
1	740	740	740	?		-1 Sl	0	0:02	NetworkManager
740	1463	1463	740	?		-1 S	0	0:00	\. /sbin/dhclient -d -sf /usr/lib/NetworkM
1	751	751	751	?		-1 Ss	0	0:00	gdm-binary
751	985	751	751	?		-1 S	0	0:00	\. /usr/lib/gdm/gdm-simple-slave --display
985	1102	1102	1102	ttg?		1102 Ps*	0	3:42	\. /usr/bin/X :0 -br -verbose -auth /v
985	1346	751	751	?		-1 S	0	0:00	\. /usr/lib/gdm/gdm-session-worker
1346	1361	1361	1361	?		-1 Sl	1000	0:00	\. gnome-session
1361	1413	1413	1413	?		-1 Ss	1000	0:00	\. /usr/bin/ssh-agent /usr/bin
1361	1446	1446	1446	?		-1 Ss	1000	0:00	\. /usr/bin/seahorse-agent --e
1361	1789	1361	1361	?		-1 S	1000	0:00	\. /bin/sh /usr/bin/compiz
1789	1934	1361	1361	?		-1 R	1000	0:48	\. /usr/bin/compiz.real --
1934	1984	1984	1984	?		-1 Ss	1000	0:00	\. /bin/sh -c /usr/bin
1984	1985	1984	1984	?		-1 S	1000	0:11	\. /usr/bin/gtk-wi
1361	1995	1361	1361	?		-1 S	1000	0:16	\. gnome-panel
1361	1997	1361	1361	?		-1 S	1000	0:04	\. nautilus
1361	1912	1361	1361	?		-1 S	1000	0:01	\. gnome-power-manager
1361	1913	1361	1361	?		-1 Sl	1000	0:00	\. /usr/lib/evolution/2.28/evo
1361	1915	1361	1361	?		-1 S	1000	0:00	\. /usr/lib/polkit-gnome/1-gnome/
1361	1917	1361	1361	?		-1 S	1000	0:00	\. bluetooth-appllet
1361	1918	1361	1361	?		-1 S	1000	0:01	\. update-notifier --startup-d
1361	1921	1361	1361	?		-1 S	1000	0:00	\. gkchm /usr/share/system-co
1361	1931	1361	1361	?		-1 S	1000	0:00	\. /usr/lib/gnome-disk-utilit

Exercise: work out how to do this on your favorite Unix or Linux machine...

Fork in action

```

pid_t p = fork();
if ( p < 0 ) {
    // Error...
    exit(-1);
} else if ( p == 0 ) {
    // We're in the child
    execlp("/bin/ls", "ls", NULL);
} else {
    // We're a parent.
    // p is the pid of the child
    wait(NULL);
    exit(0);
}
    
```

Return code from fork() tells you whether you're in the parent or child (cf. setjmp())

Child process can't actually be cleaned up until parent “waits” for it.

Process state diagram for Unix

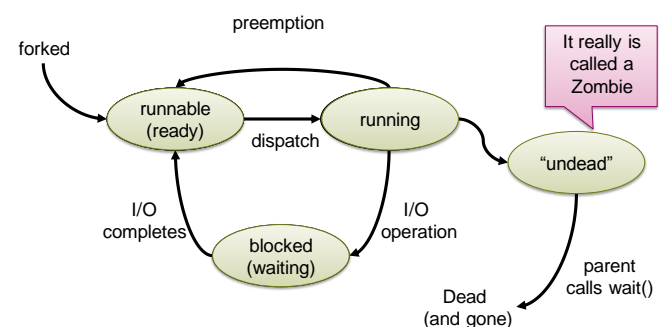

Kernel Threads

31

How do threads fit in?

- It depends...
- **Types of threads:**
 - Kernel threads
 - One-to-one user-space threads
 - Many-to-one
 - Many-to-many
- **Do NOT confuse this with hardware threads/SMT/Hyperthreading**
 - In these, the CPU offers more physical resources for threads!

32

Kernel threads

- **Kernels can (and some do) implement threads**
- **Multiple execution contexts inside the kernel**
 - Much as in a JVM
- **Says nothing about user space**
 - Context switch still required to/from user process
- **First, how many stacks are there in the kernel?**

33

Process switching

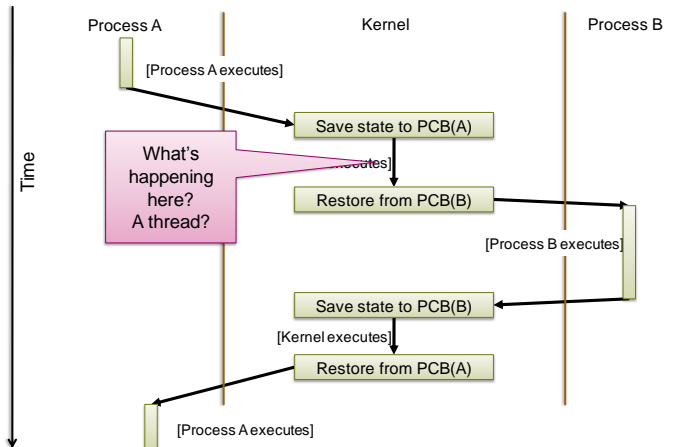

34

Kernel architecture

- **Basic Question: How many kernel stacks?**
- **Unix 6th edition has a kernel stack per process**
 - Arguably complicates design
 - Q. On which stack does the thread scheduler run?
 - A. On the first thread (#1)
 - ⇒ Every context switch is actually *two*!
 - Linux et al. replicate this, and try to optimize it.
- **Others (e.g., Barrelfish) have only one kernel stack per CPU**
 - Kernel must be purely event driven: no long-running kernel tasks
 - More efficient, less code, harder to program (some say).

35

Process switching revisited

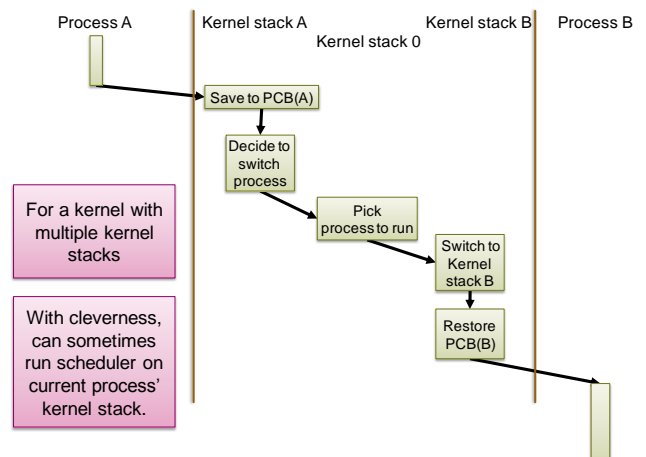

36



System Calls in more detail

- **We can now say in more detail what happens during a system call**
- **Precise details are very dependent on OS and hardware**
 - Linux has 3 different ways to do this for 32-bit x86 *alone!*
- **Linux:**
 - Good old int 0x80 or 0x2e (software interrupt, syscall number in EAX)
Set up registers and call handler
 - Fast system calls (sysenter/sysexit, >Pentium II)
CPU sets up registers automatically

<http://www.int80h.org/> ©

37



Performing a system call

In user space:

1. Marshall the arguments somewhere safe
2. Saves registers
3. Loads system call number
4. Executes SYSCALL instruction (or SYSENTER, or INT 0x80, or..)
5. And?

38



System calls in the kernel

- **Kernel entered at fixed address**
 - Privileged mode is set
- **Need to call the right function and return, so:**
 1. Save user stack pointer and return address
 - *In the Process Control Block*
 2. Load SP for this process' *kernel* stack
 3. Create a C stack frame on the kernel stack
 4. Look up the syscall number in a jump table
 5. Call the function (e.g., `read()`, `getpid()`, `open()`, etc.)

39



Returning in the kernel

- **When function returns:**
 1. Load the user space stack pointer
 2. Adjust the return address to point to:
Return path in user space back from the call, OR
Loop to retry system call if necessary
 3. Execute "syscall return" instruction
- **Result is execution back in user space, on user stack**
- **Alternatively, can do this to a different process...**

40



User-space threads

41



From now on assume:

- **Previous example was Unix 6th Edition:**
 - Which had *no* threads *per se*, only processes
 - i.e., Process ↔ Kernel stack
- **From now on, we'll assume:**
 - Multiple kernel threads per CPU
 - Efficient kernel context switching
- **How do we implement user-visible threads?**

42

What are the options?

1. **Implement threads within a process (one kernel thread)**
 2. **Multiple kernel threads in a process**
 3. **Some combination of the above**
- **and other more unusual cases we won't talk about...**

43

Many-to-one threads

- **Early “thread libraries”**
 - Green threads (original Java VM)
 - GNU Portable Threads
 - Standard student exercise: implement them!
- **Sometimes called “pure user-level threads”**
 - aka. lightweight threads, tasks (differences in control)
 - No kernel support required
 - Also (confusingly) “Lightweight Processes”

44

Many-to-one threads

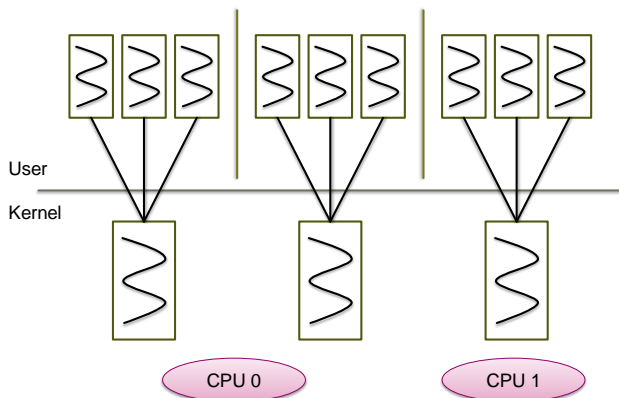

45

Address space layout for user level threads

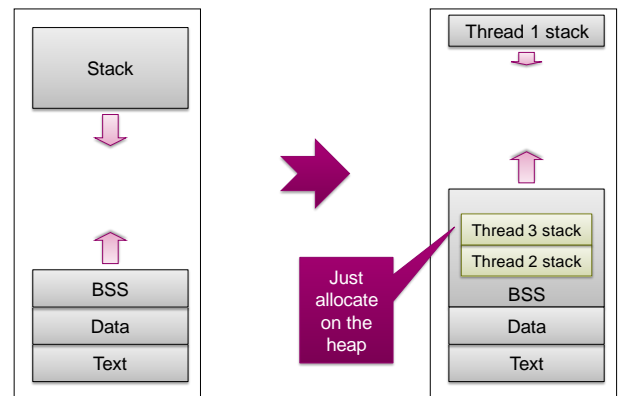

46

One-to-one user threads

- **Every user thread is/has a kernel thread.**
- **Equivalent to:**
 - multiple processes sharing an address space
 - Except that “process” now refers to a group of threads
- **Most modern OS threads packages:**
 - Linux, Solaris, Windows XP, MacOSX, etc.

47

One-to-one user threads

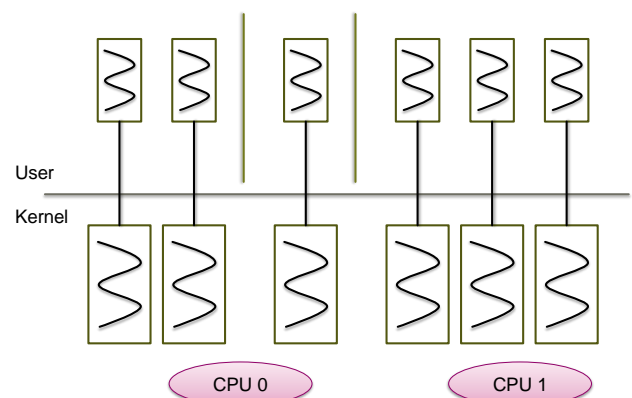

48

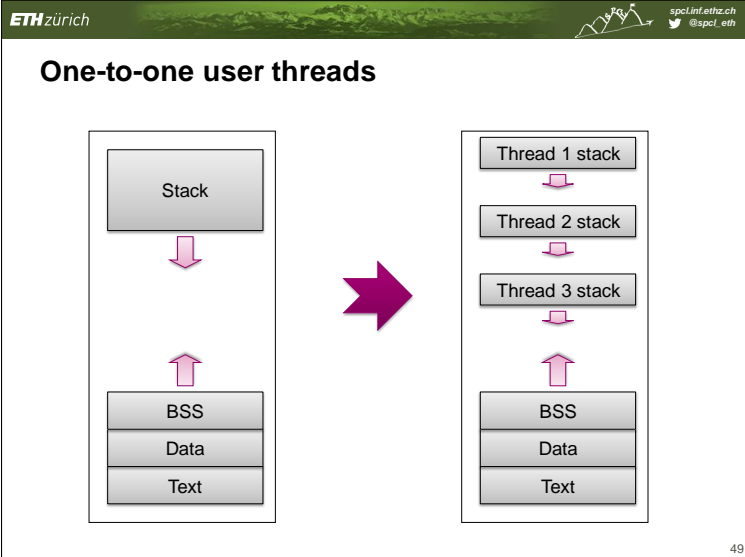

ETH zürich spcl.inf.ethz.ch @spcl_eth

Comparison

<p>User-level threads</p> <ul style="list-style-type: none"> ▪ Cheap to create and destroy ▪ Fast to context switch ▪ Can block entire process <ul style="list-style-type: none"> ▪ Not just on system calls 	<p>One-to-one threads</p> <ul style="list-style-type: none"> ▪ Memory usage (kernel stack) ▪ Slow to switch ▪ Easier to schedule ▪ Nicely handles blocking
--	---

50

ETH zürich spcl.inf.ethz.ch @spcl_eth

Many-to-many threads

- Multiplex user-level threads over several kernel-level threads
- Only way to go for a multiprocessor
 - I.e., pretty much everything these days
- Can “pin” user thread to kernel thread for performance/predictability
- Thread migration costs are “interesting”...

51

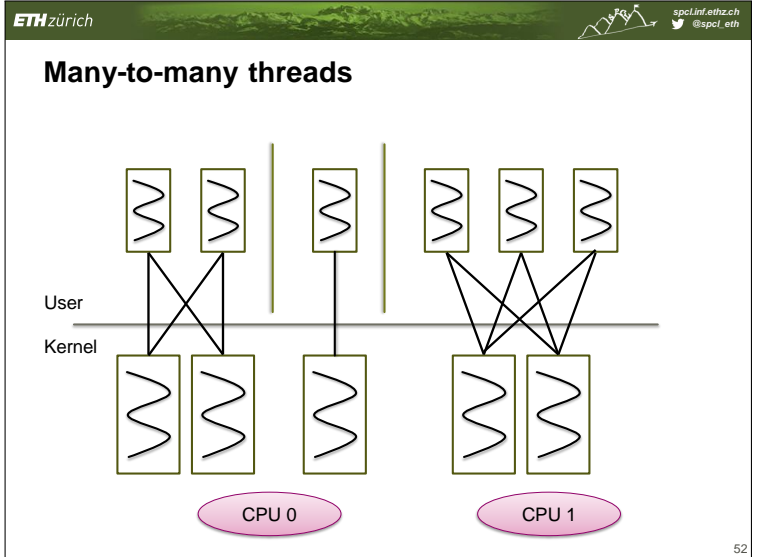

ETH zürich spcl.inf.ethz.ch @spcl_eth

Next week

- **Synchronization:**
 - How to implement those useful primitives
- **Interprocess communication**
 - How processes communicate
- **Scheduling:**
 - Now we can pick a new process/thread to run, how do we decide which one?

53