

Mikhail Khalilov, Marcin Chrapek, Siyuan Shen, Alessandro Vezzu, Thomas Benz, Salvatore Di Girolamo, and Timo Schneider, *ETH Zürich*
Daniele De Sensi, *ETH Zürich and Sapienza University of Rome*
Luca Benini and Torsten Hoefler, *ETH Zürich*

OSMOSIS: Enabling Multi-Tenancy in Datacenter SmartNICs



Why SmartNICs?

Gap between CPU and NIC bandwidth

ConnectX-2 (2009): 10Gbps/port



ConnectX-7 (2023): 400 Gbps/port

CPU bandwidth scales slower than the NIC bandwidth

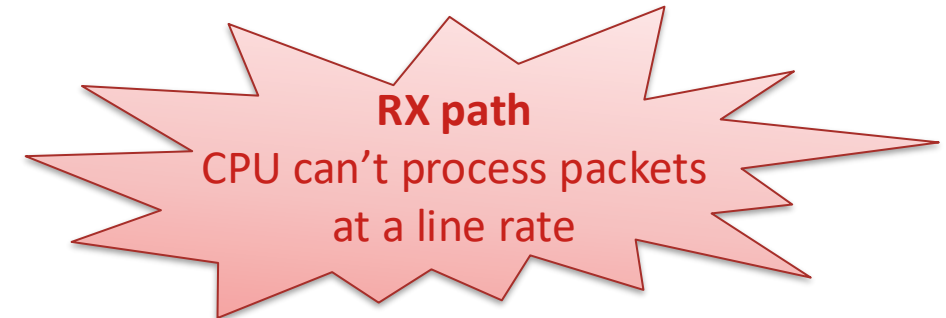
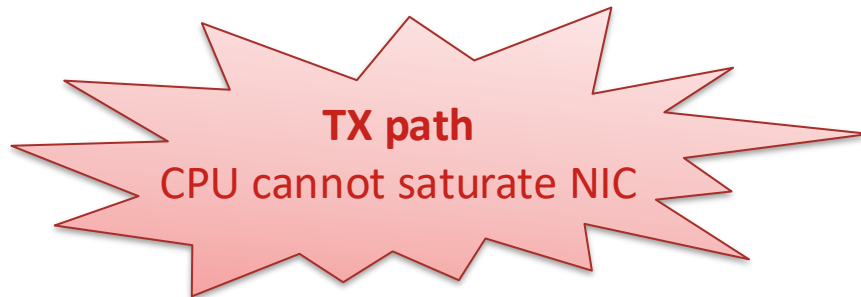

SmartNIC offloading approach:
free CPU cycles by offloading “hot” parts of the host-side stack to the NIC data path

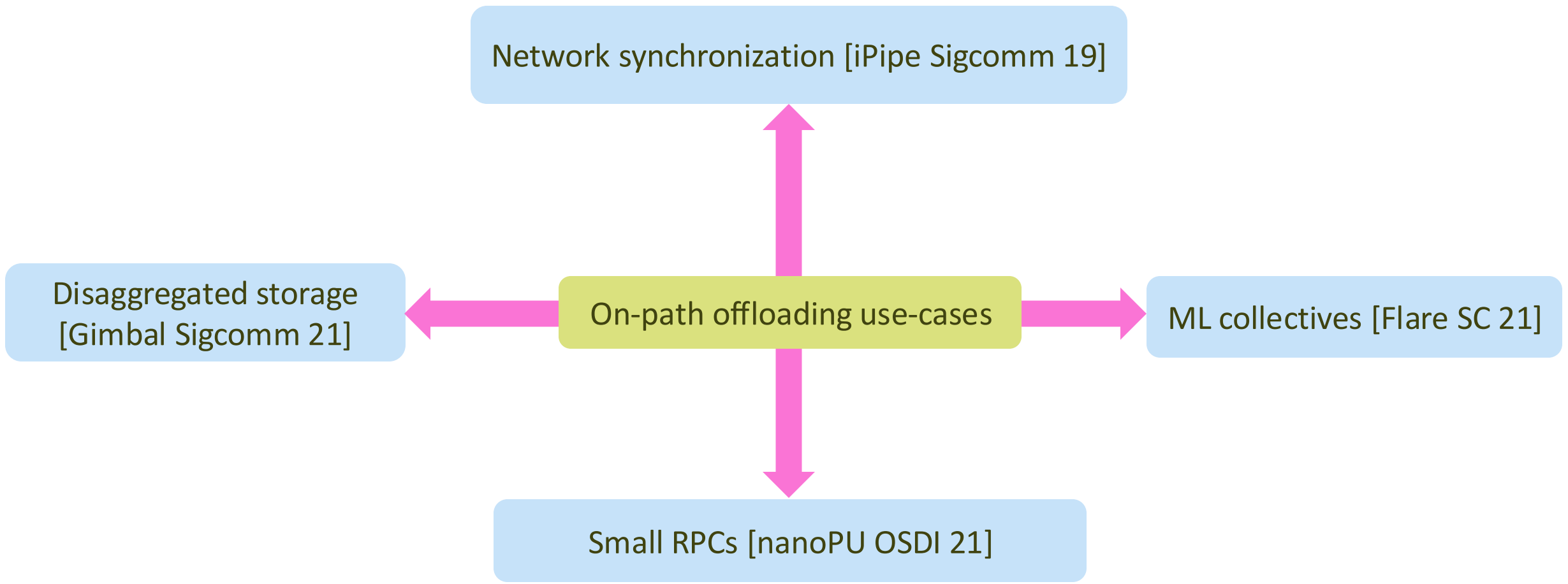

SmartNIC offloading

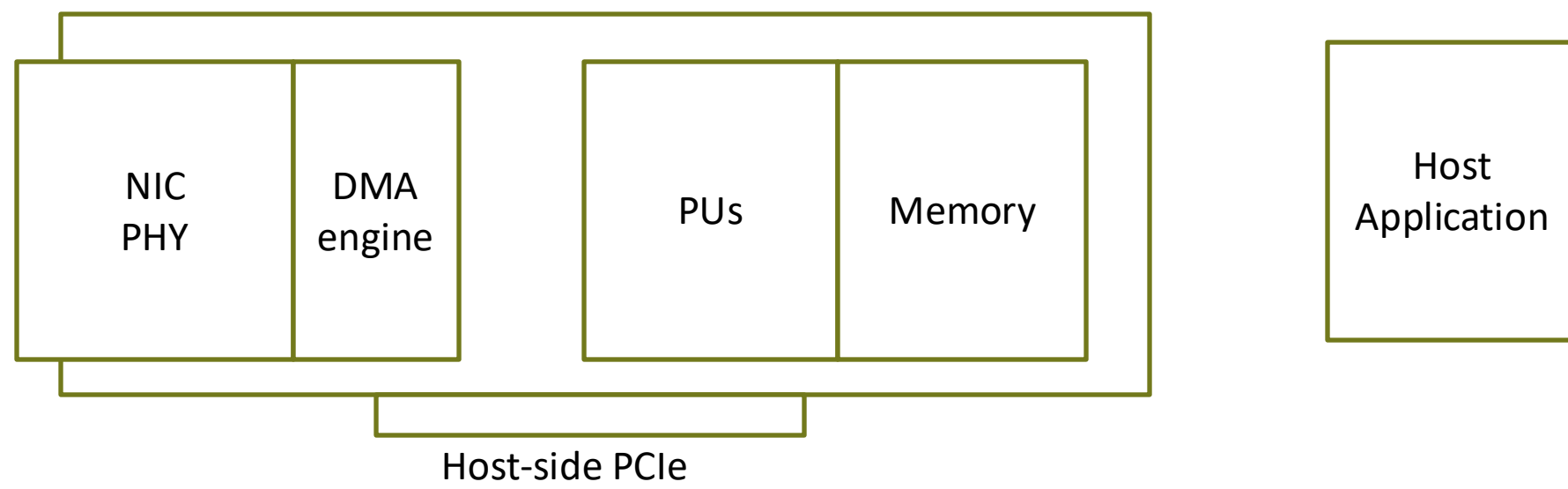

SmartNIC offloading

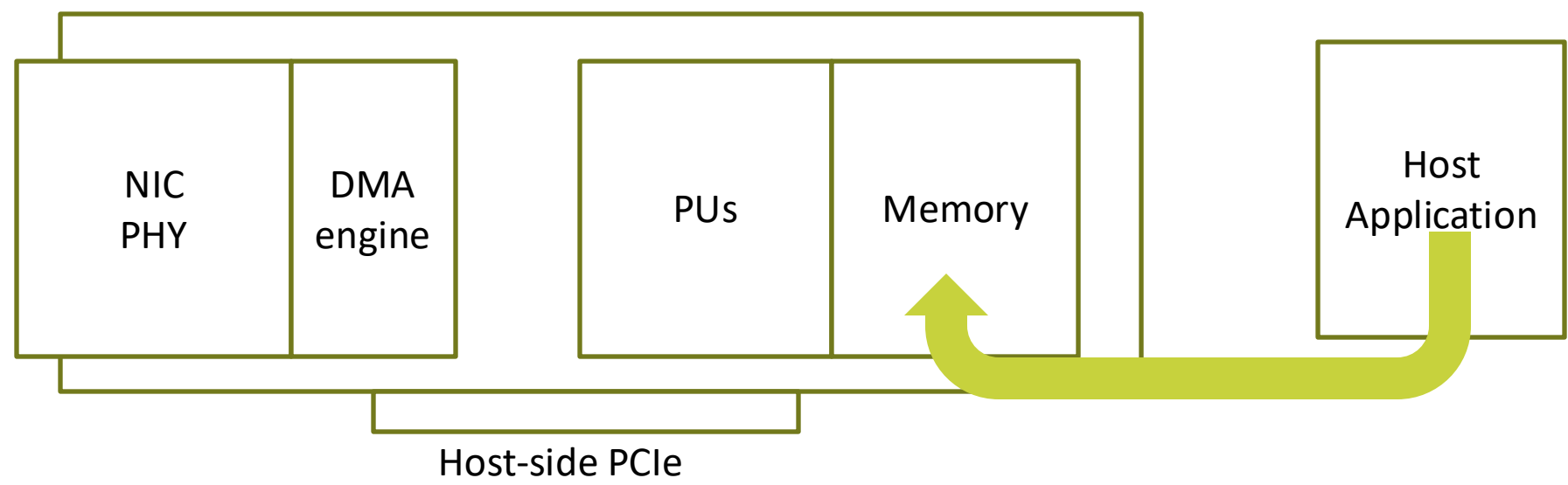

SmartNIC offloading

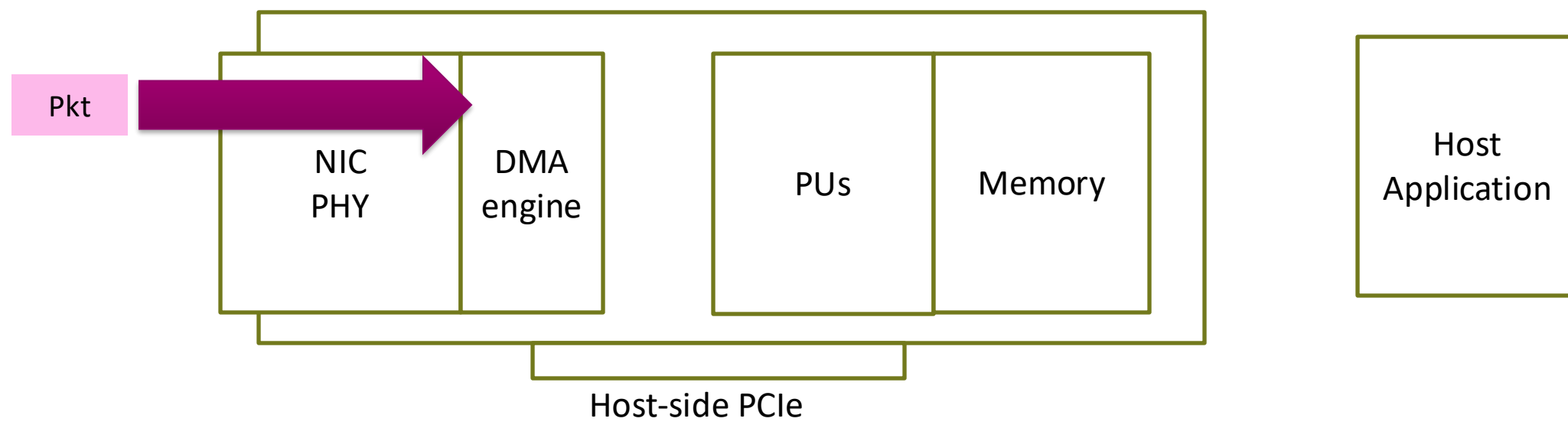

SmartNIC offloading

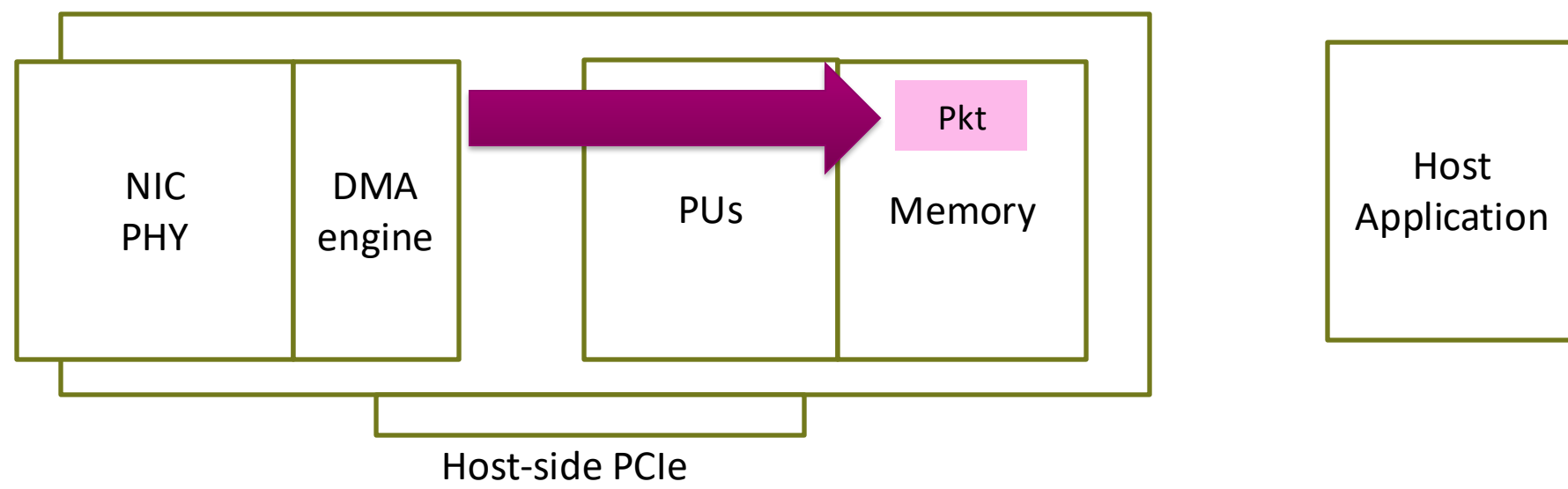

SmartNIC offloading

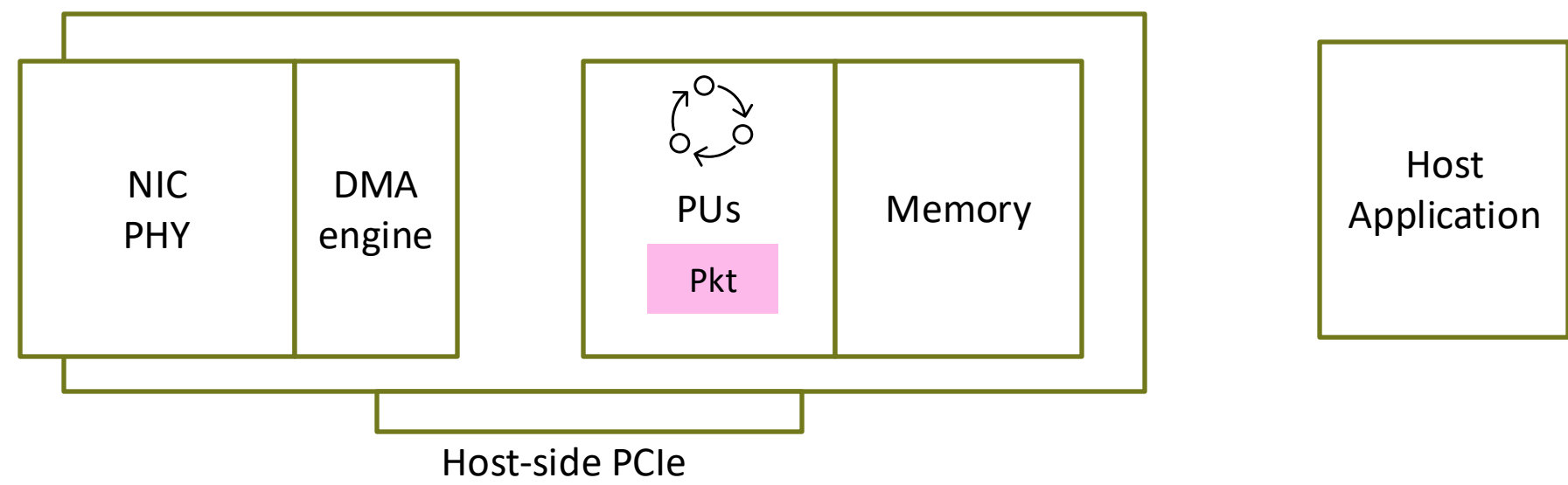

SmartNIC offloading

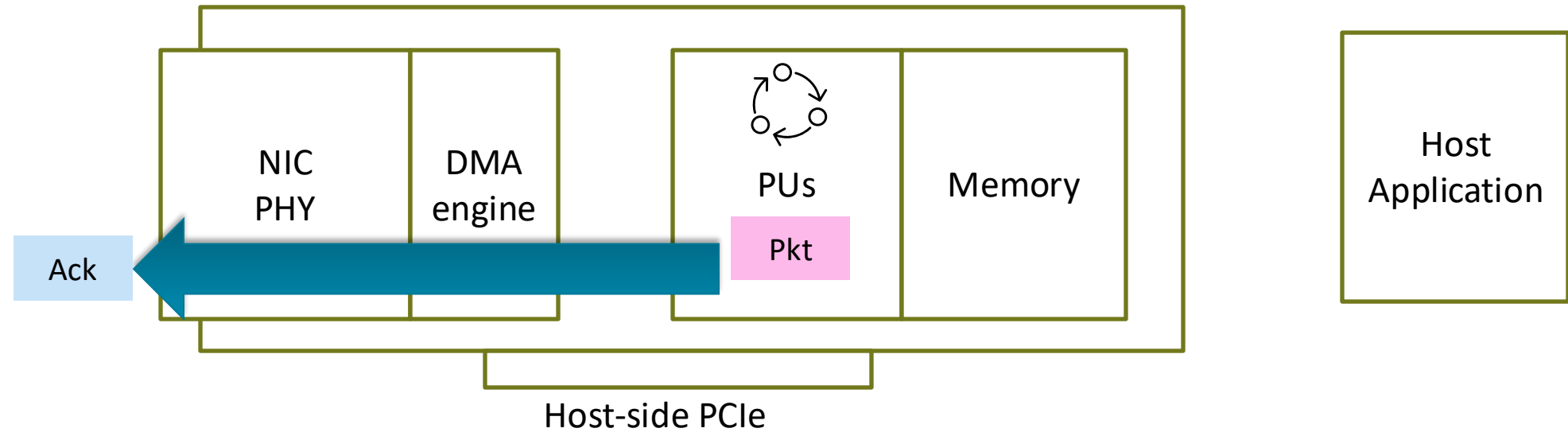

SmartNIC offloading

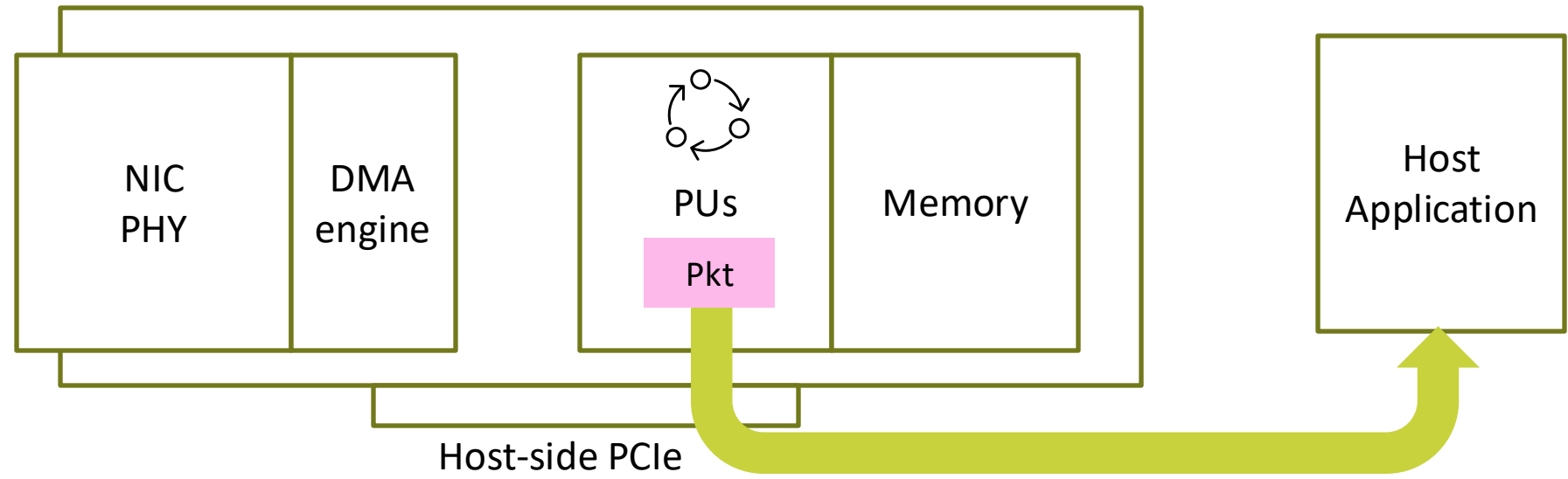

State-of-the-art: *on-path* vs *off-path* offloading

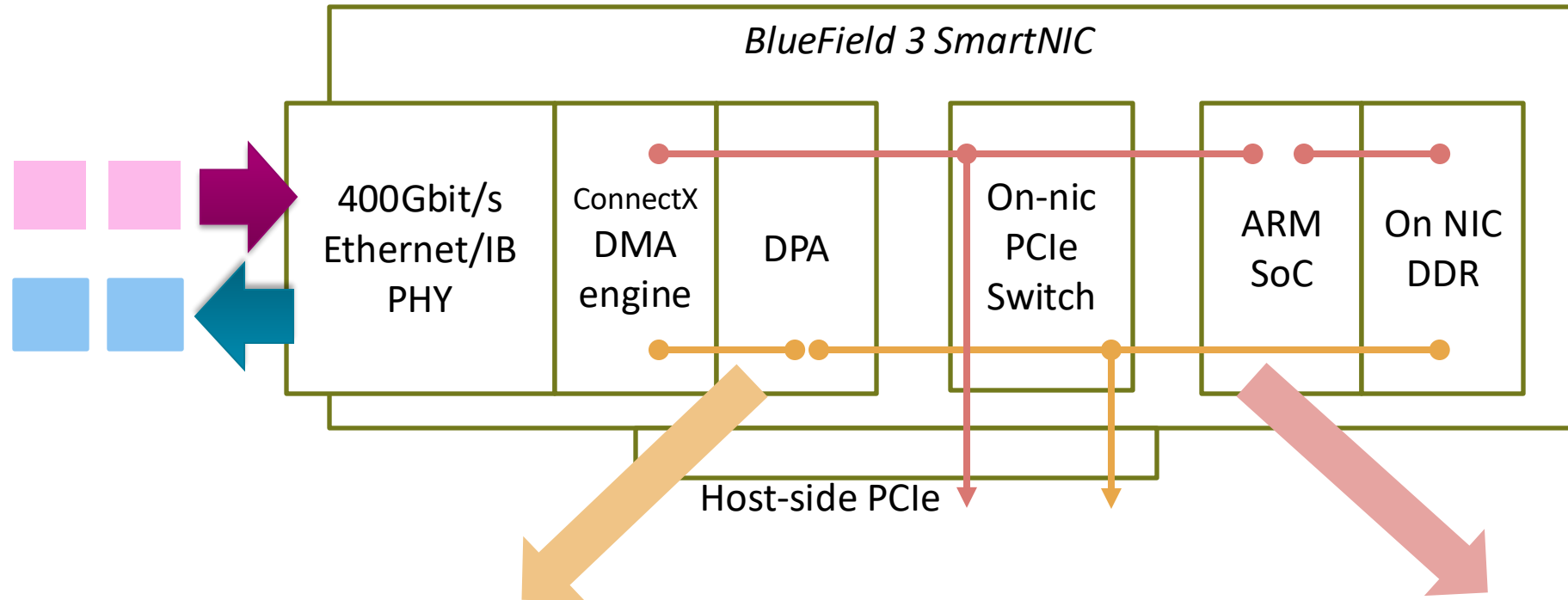

On-path: Data Path Accelerator (DPA)

16 hyper-threaded RISC-V cores: 256 hardware threads
 Ideal for low-IPC highly-parallel workloads
 C API to interact with DMA/accelerators

Off-path: ARM SoC

16 superscalar OOO ARM cores
 Tailored for single-thread-bound workloads
 Linux RDMA/DOCA stacks

In our work we focus on the on-path offloading

Q: What will happen if we'll share SmartNIC resources between tenants?

A: Let's take an open-source SmartNIC and see!

Open-source PsPIN on-path SmartNIC

- Software/hardware stack based on energy-efficient RISC-V PUs
- Support for general-purpose per-packet processing with C
- Offloading is very similar to the NVIDIA BlueField Datapath Accelerator

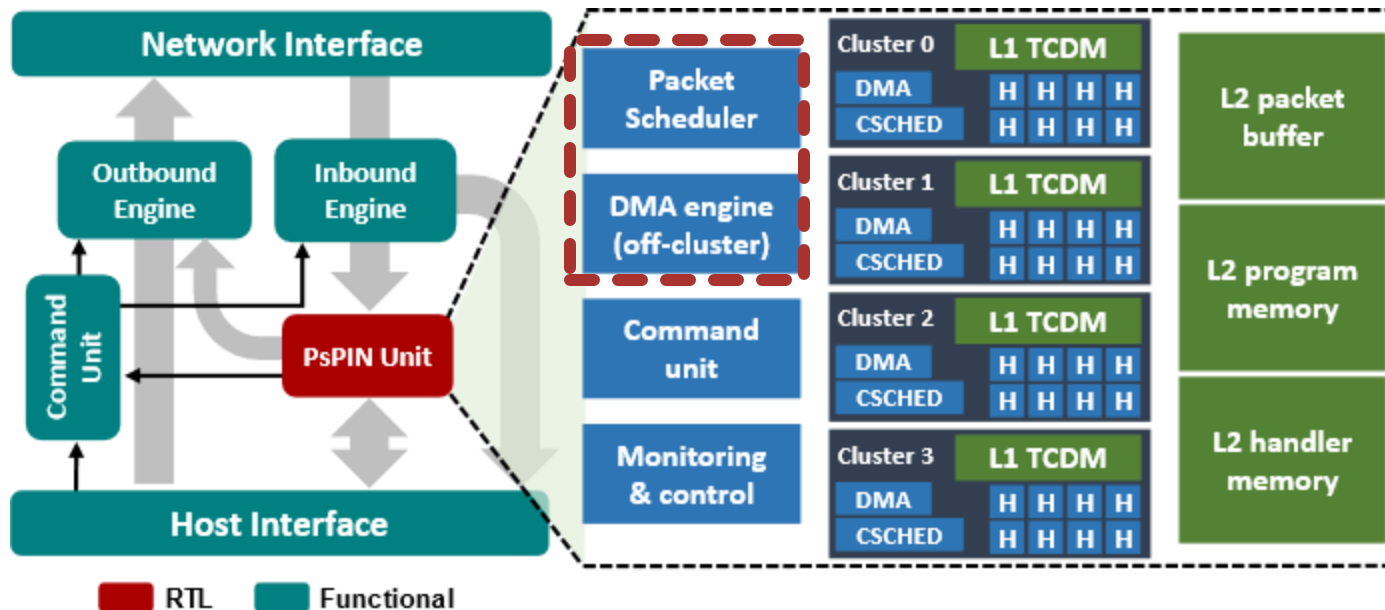

What are the implications of resource sharing for DMA engine and PUs between tenants?

[Di Girolamo et. al., ISCA 48]

In-network compute (INC) management

Victim tenant needs 2x less PU cycles to process single packet

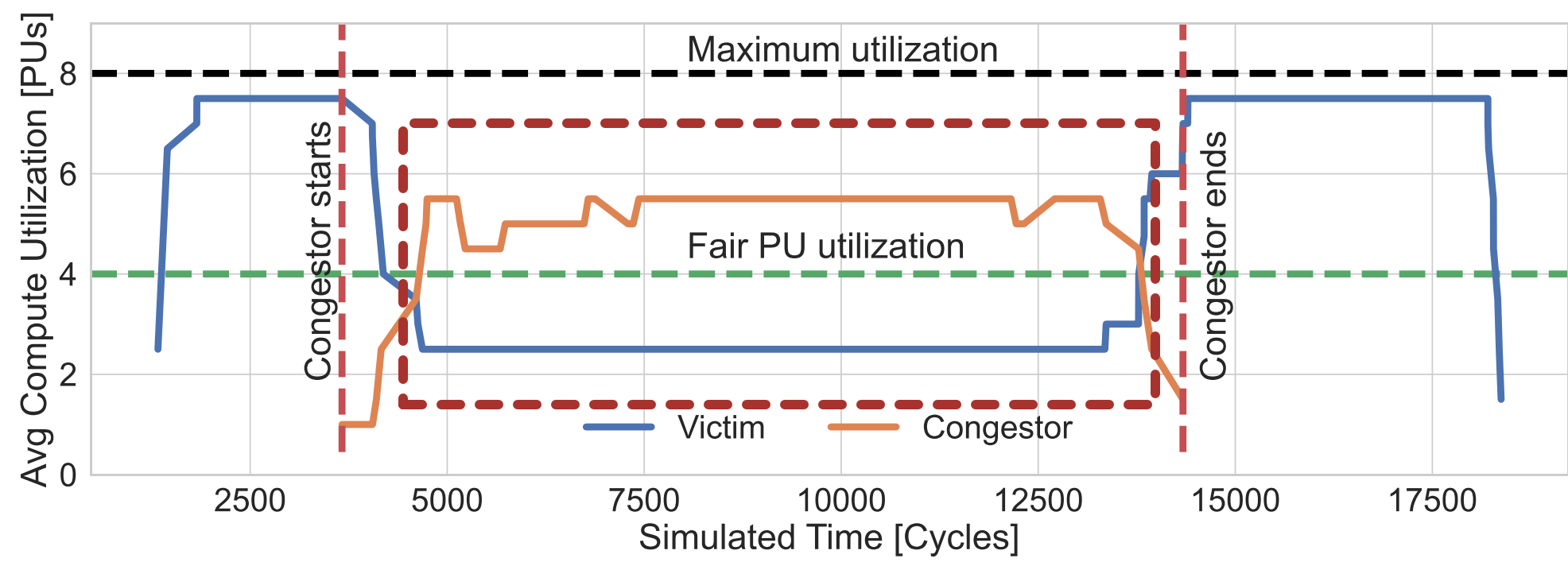

Conventional round robin scheduling for compute engines is unfair

IO management

Two tenants offload kernels to serve IO RPCs of different sizes

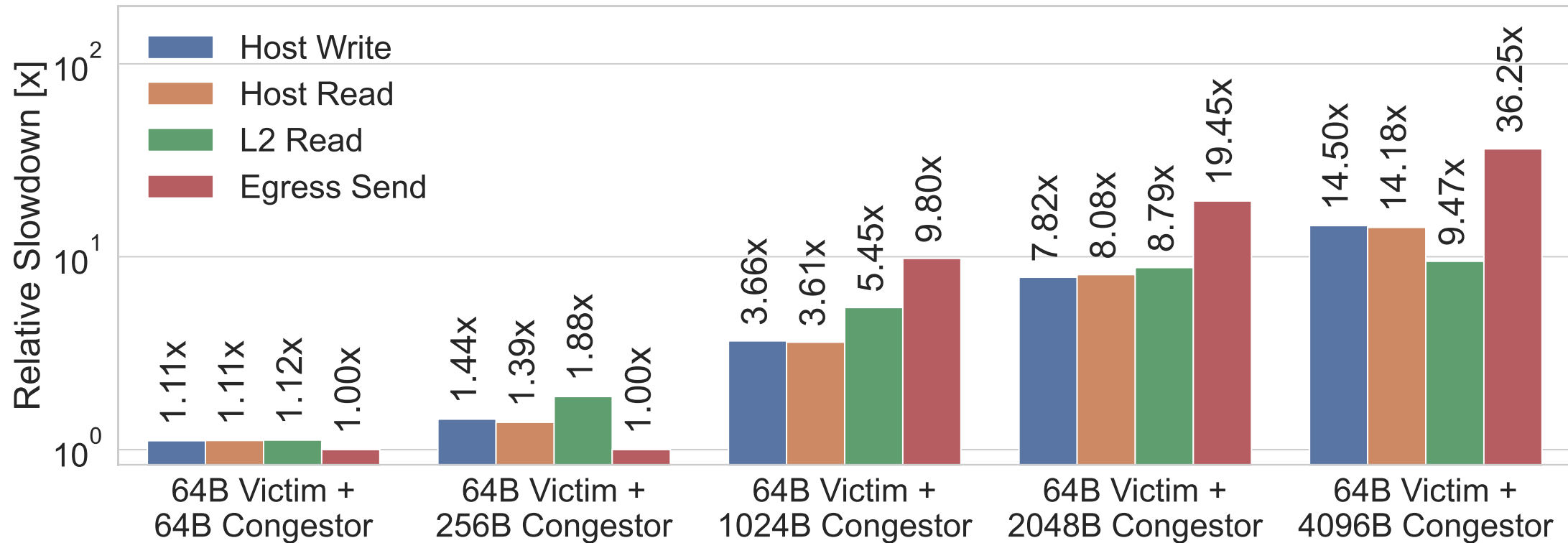

FIFO processing of DMA requests results in HoL-blocking

... but why not use standard OS schedulers?

Packet processing deadlines at 400 Gbit/s and 1 GHz

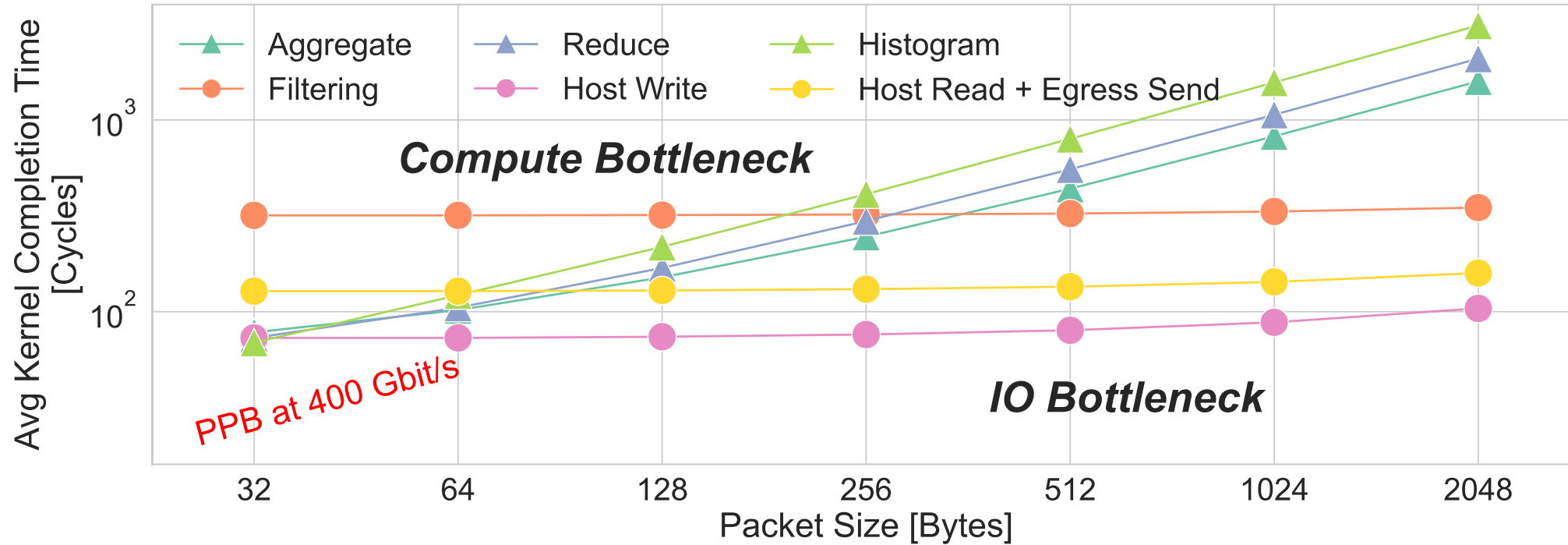

<1 us to process packet

Software packet scheduling is not feasible

OSMOSIS

OSMOSIS: Operating System Support for Streaming In-Network Processing

- Hardware-based resource management designed for next-generation on-path SmartNICs
- Dynamic and work-conserving IO/compute tenant resource management
- Support for data-center SLOs and priority enforcement

	PU s	DMA	Egress	Memory
Scheduler	WLBVT	WRR	WRR	Static
SLO knob	Priority Kernel cycle limit	Priority	Priority	Allocation size

OSMOSIS overview

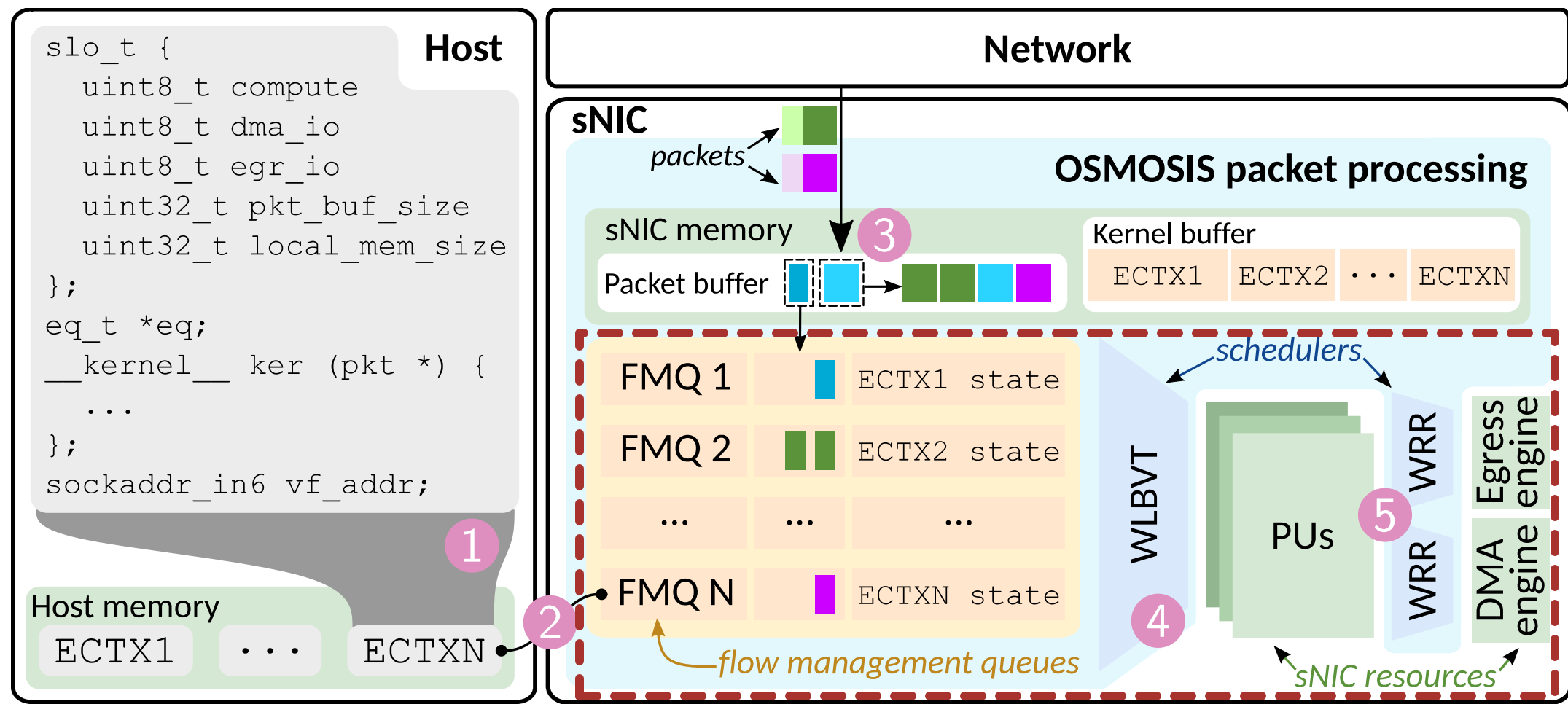

OSMOSIS compute management: WLBVT scheduler

Weight-limited Borrowed Virtual Time

Inspired by the BVT [SOSP-17] and Shinjuku [NSDI '19] schedulers

- Track how many PUs/cycle the FMQs need
- Choose the FMQ with the smallest number of used cycles

Use WRR-like weights to support priorities

- Scale down number of used cycles according to priority

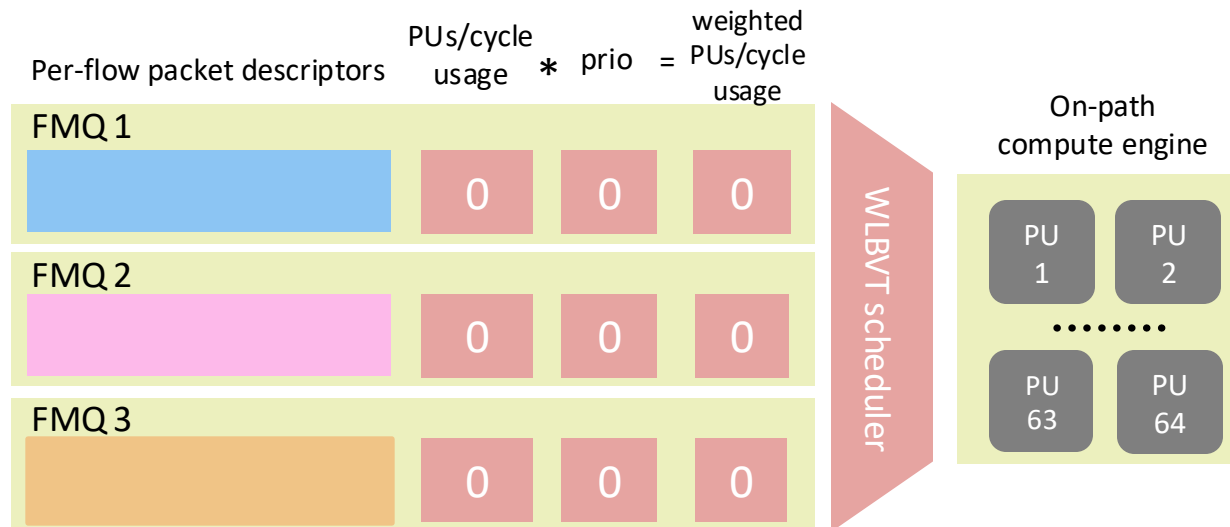

Initial system state:
All PUs are idle

OSMOSIS compute management: WLBVT scheduler

Weight-limited Borrowed Virtual Time

Inspired by the BVT [SOSP-17] and Shinjuku [NSDI '19] schedulers

- Track how many PUs/cycle the FMQs need
- Choose the FMQ with the smallest number of used cycles

Use WRR-like weights to support priorities

- Scale down number of used cycles according to priority

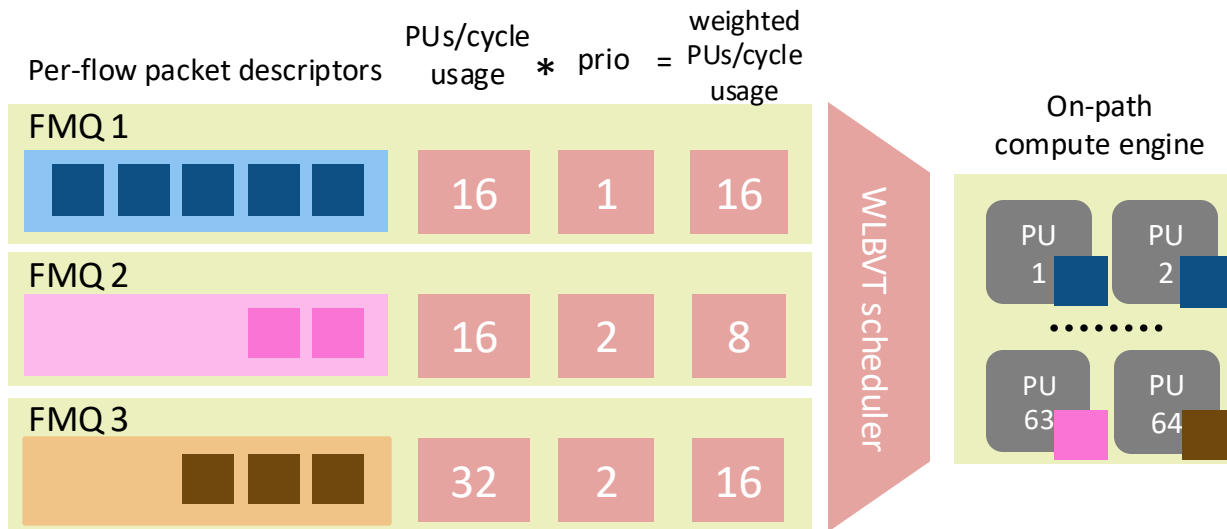

System state at cycle N:
All PUs are busy

OSMOSIS compute management: WLBVT scheduler

Weight-limited Borrowed Virtual Time

Inspired by the BVT [SOSP-17] and Shinjuku [NSDI '19] schedulers

- Track how many PUs/cycle the FMQs need
- Choose the FMQ with the smallest number of used cycles

Use WRR-like weights to support priorities

- Scale down number of used cycles according to priority

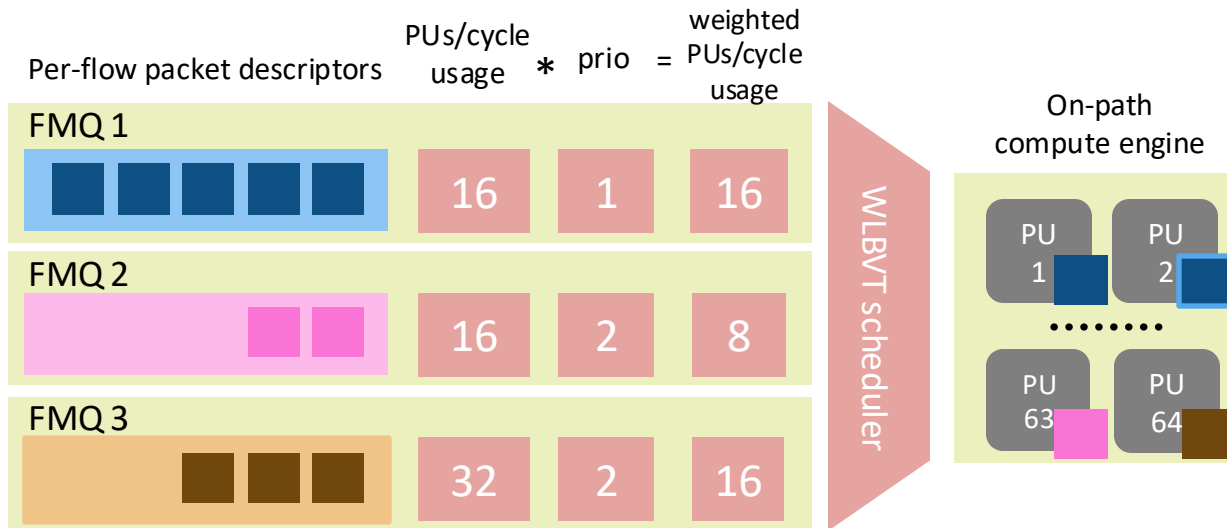

System state at cycle N + 1:
PU 2 finishes processing FMQ 1 packet

OSMOSIS compute management: WLBVT scheduler

Weight-limited Borrowed Virtual Time

Inspired by the BVT [SOSP-17] and Shinjuku [NSDI '19] schedulers

- Track how many PUs/cycle the FMQs need
- Choose the FMQ with the smallest number of used cycles

Use WRR-like weights to support priorities

- Scale down number of used cycles according to priority

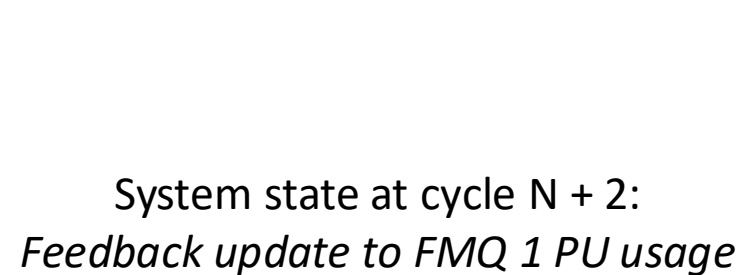
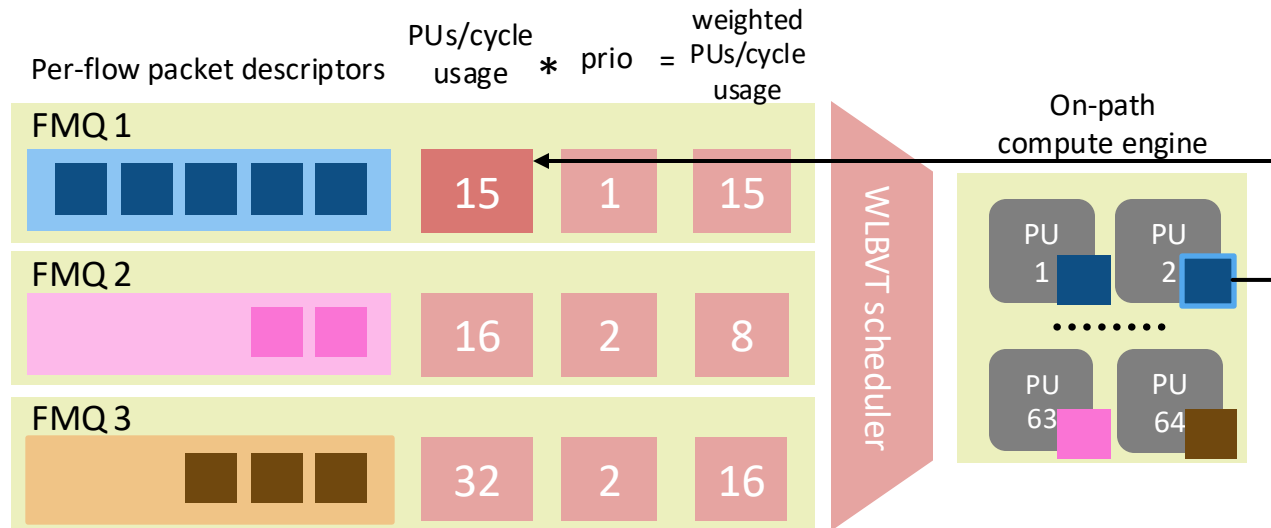

OSMOSIS compute management: WLBVT scheduler

Weight-limited Borrowed Virtual Time

Inspired by the BVT [SOSP-17] and Shinjuku [NSDI '19] schedulers

- Track how many PUs/cycle the FMQs need
- Choose the FMQ with the smallest number of used cycles

Use WRR-like weights to support priorities

- Scale down number of used cycles according to priority

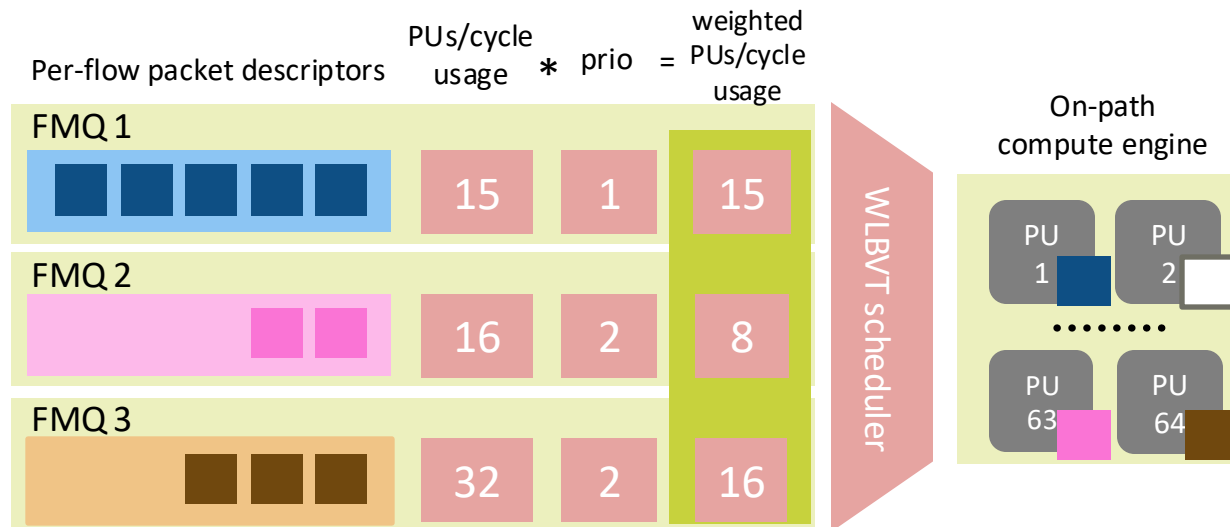

System state at cycle N + 3:
Find FMQ with minimal PU usage

OSMOSIS compute management: WLBVT scheduler

Weight-limited Borrowed Virtual Time

Inspired by the BVT [SOSP-17] and Shinjuku [NSDI '19] schedulers

- Track how many PUs/cycle the FMQs need
- Choose the FMQ with the smallest number of used cycles

Use WRR-like weights to support priorities

- Scale down number of used cycles according to priority

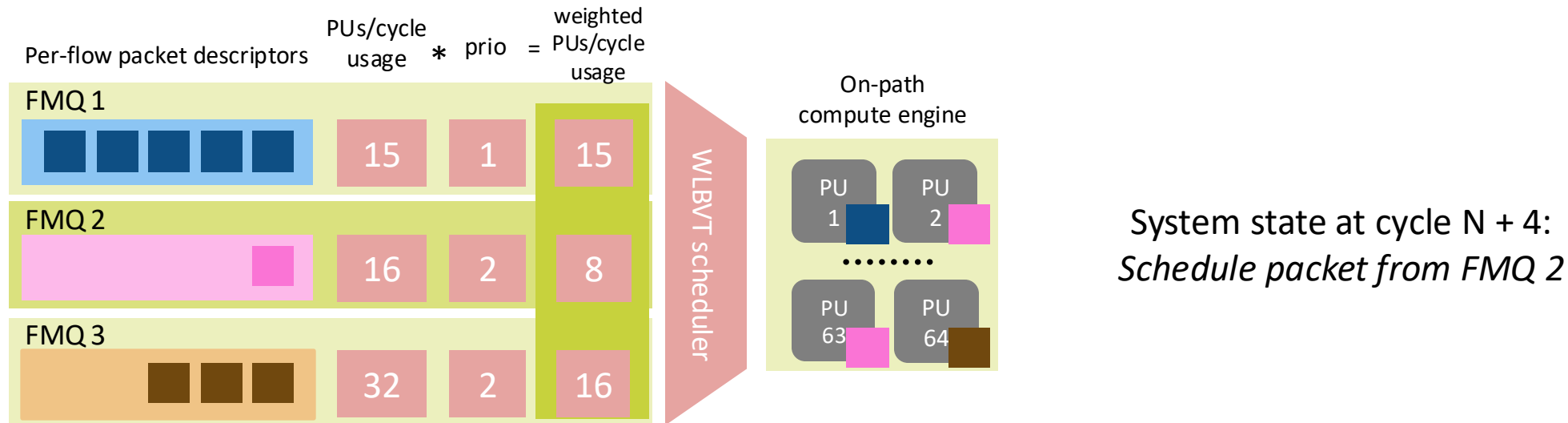

OSMOSIS compute management: WLBVT scheduler

Weight-limited Borrowed Virtual Time

Inspired by the BVT [SOSP-17] and Shinjuku [NSDI '19] schedulers

- Track how many PUs/cycle the FMQs need
- Choose the FMQ with the smallest number of used cycles

Use WRR-like weights to support priorities

- Scale down number of used cycles according to priority

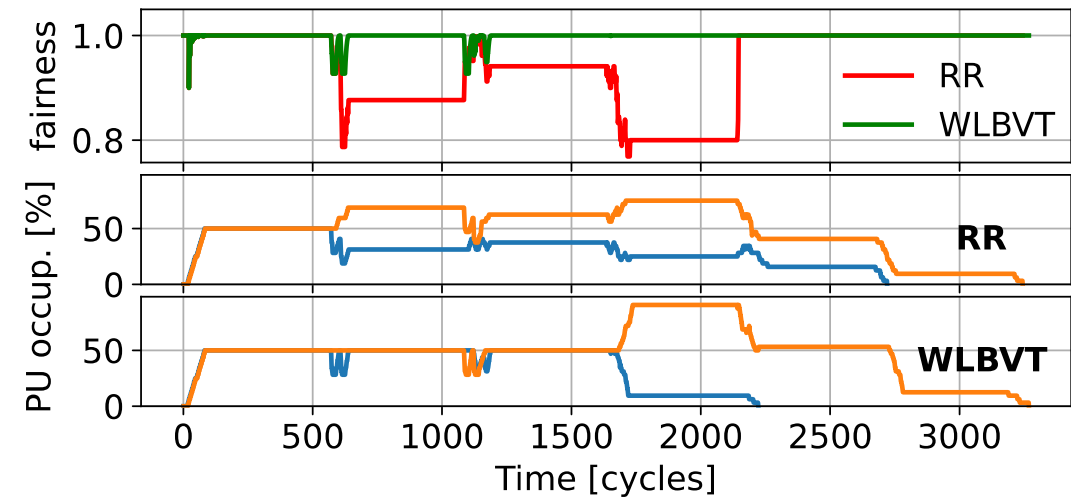
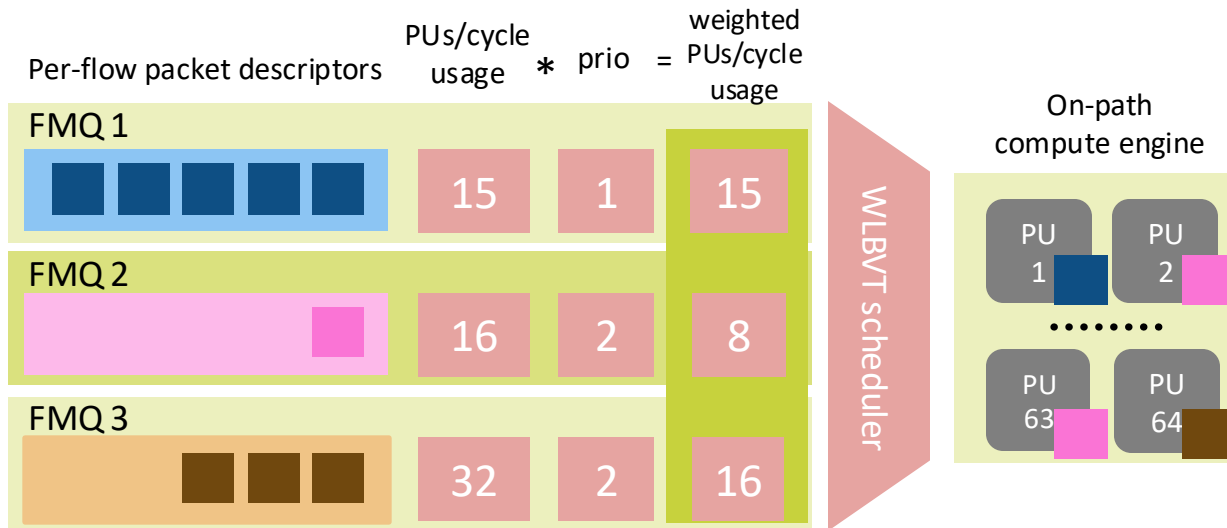

OSMOSIS IO management

- **WRR scheduling**
- **DMA request fragmentation**
 - Software: split large requests into smaller ones
 - Hardware: keep per-AXI-stream state

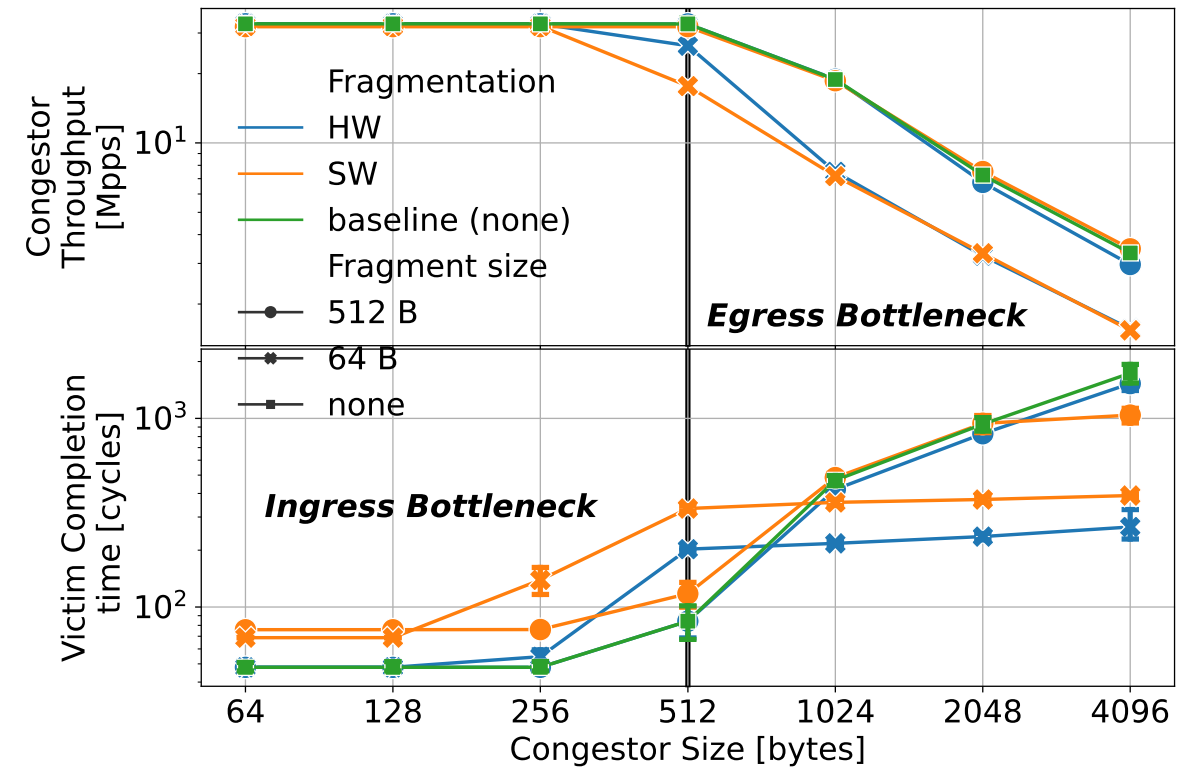

Evaluation

Experimental testbed

Synthesis with Synopsys Design Compiler NXT

- GlobalFoundries 22nm process

Cycle-accurate simulation with Verilator

- 32 1 GHz RISC-V PUs
- 400 Gbit/s ingress/egress link

Compared systems

- Baseline vanilla PsPIN SmartNIC
- OSMOSIS-enhanced PsPIN

Hardware footprint analysis

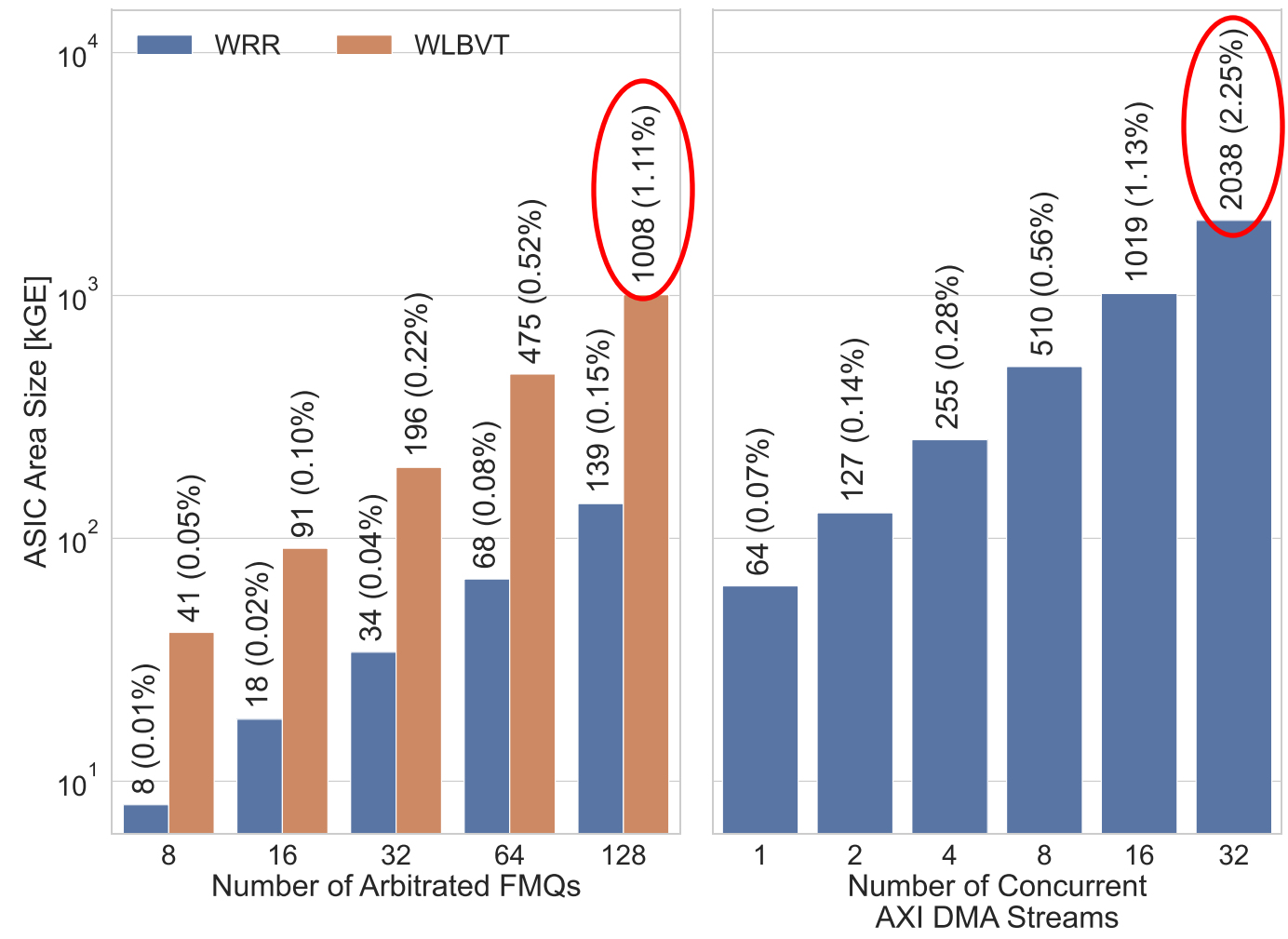

Resource isolation performance

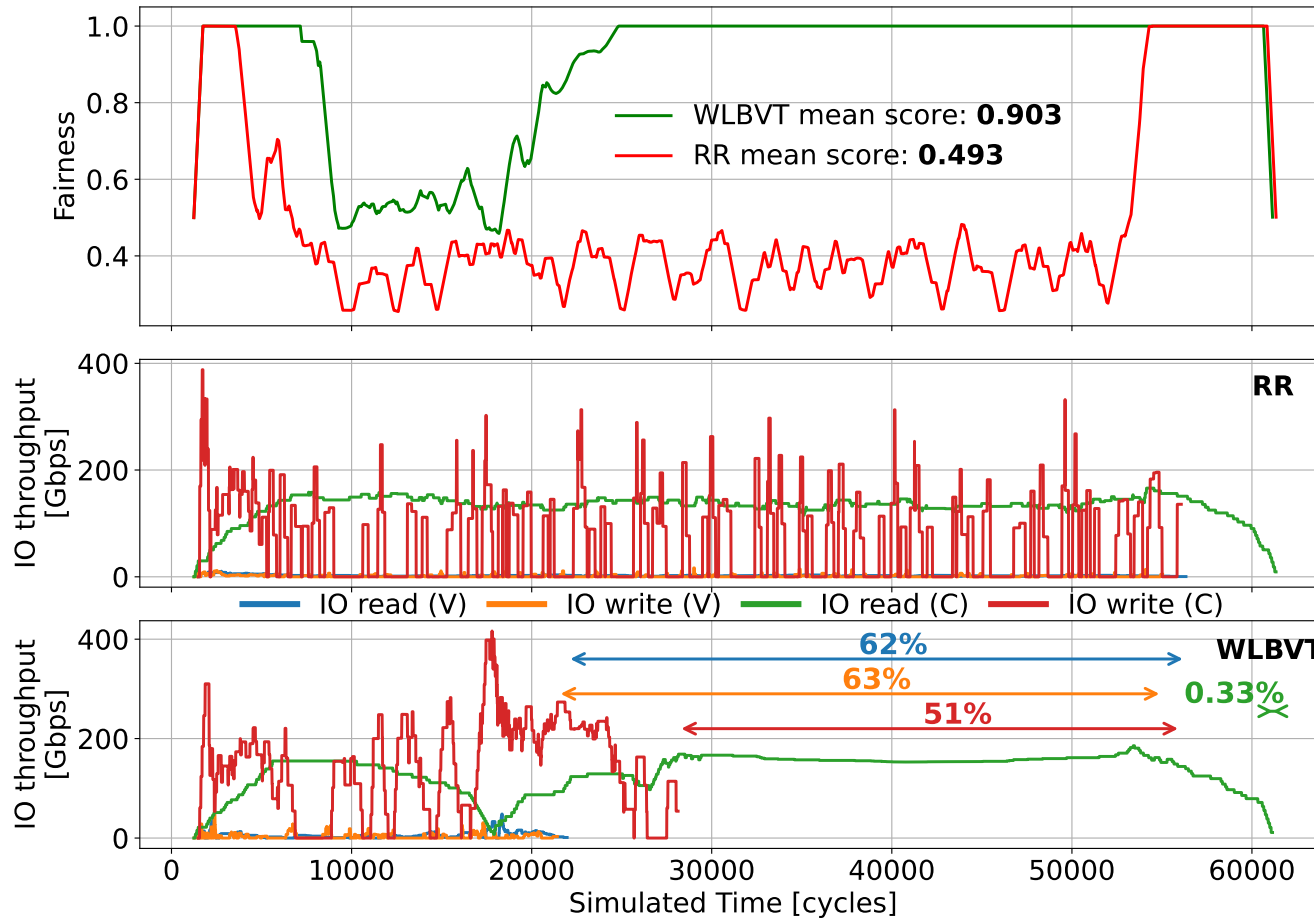

IO read = DMA read + Egress send
IO write = DMA write

Victims issue up to 128 KB requests
Congestors issue up to 4 KB requests

Conclusions

More of SPCL's research:

General scenario: Arbitrary complexity of tenant kernels

We need a dynamic SmartNIC resource management that maintains fairness across tenants with different resource requirements!

OSMOSIS overview

```

slo_t {
  uint8_t compute
  uint8_t dma_io
  uint8_t egr_io
  uint32_t pkt_buf_size
  uint32_t local_mem_size
};
eq_t *eq;
_kernel_ ker (pkt *) {
  ...
  sockaddr_in6 vf_addr;
};
    
```

youtube.com/@spcl **180+ Talks**

twitter.com/spcl_eth **1.4K+ Followers**

github.com/spcl **3.8K+ Stars**

... or spcl.ethz.ch



OSMOSIS compute management: WLBVT scheduler

- Hybrid scheduler with minimal hardware footprint
- Inspired by the BVT [SOSP-17] and Shinjuku [NSDI '19] schedulers
 - Track how many PUs/cycle the FMQs need
 - Choose FMQ with the smallest number of used cycles
- Use WRR-like weights to support priorities
 - Scale up/down number of used cycles

Per-flow packet descriptors	PU/cycle usage	prio	weighted PU/cycle usage
FMQ 1	15	1	15
FMQ 2	16	2	8
FMQ 3	32	2	16

Resource isolation performance with IO bound mix

WLBVT mean score: **0.903**
RR mean score: **0.493**

IO read = DMA read + Egress send
IO write = DMA write

Victims issue up to 128 KB requests
Congestors issue up to 4 KB requests

WLBVT throughput: 62%, 51%, 0.33%



<https://spclgitlab.ethz.ch/mkhalilov/pspin-osmosis>

mikhail.khalilov@inf.ethz.ch

Conclusions

More of SPCL's research:

General scenario: Arbitrary complexity of tenant kernels

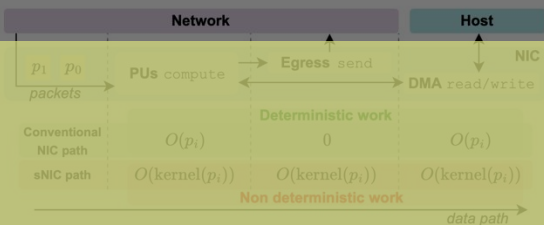

We need a dynamic SmartNIC resource management that maintains fairness across tenants with different resource requirements!

OSMOSIS overview

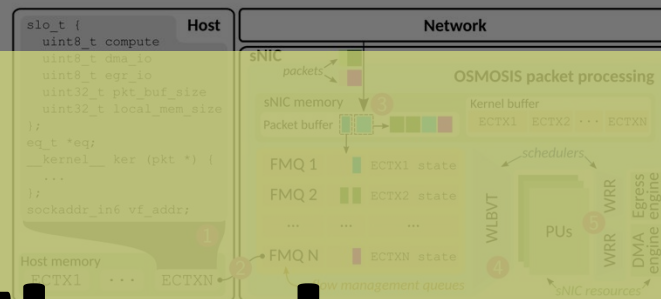

Thank you!

OSMOSIS compute management: WLBVT scheduler

- Hybrid scheduler with minimal hardware footprint
- Inspired by the BVT [SOSP-17] and Shinjuku [NSDI '19] schedulers
 - Track how many PUs/cycle the FMQs need
 - Choose FMQ with the smallest number of used cycles
- Use WRR-like weights to support priorities
 - Scale up/down number of used cycles

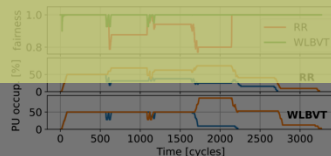

23

Resource isolation performance with IO bound mix

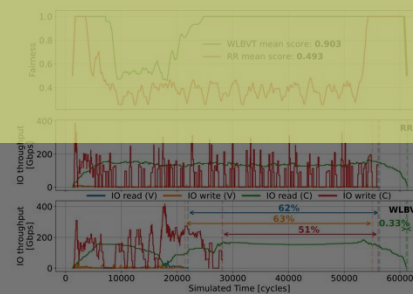

IO read = DMA read + Egress send
IO write = DMA write

Victims issue up to 128 KB requests
Congestors issue up to 4 KB requests

24

youtube.com/@spcl 180+ Talks

twitter.com/spcl_eth 1.4K+ Followers

github.com/spcl 3.8K+ Stars

... or spcl.ethz.ch



<https://spclgitlab.ethz.ch/mkhalilov/pspin-osmosis>

mikhail.khalilov@inf.ethz.ch