

TIMO SCHNEIDER <TIMOS@INF.ETHZ.CH>

DPHPC Recitation Session 3

Caches



Cache Organization – Cachelines & Sets

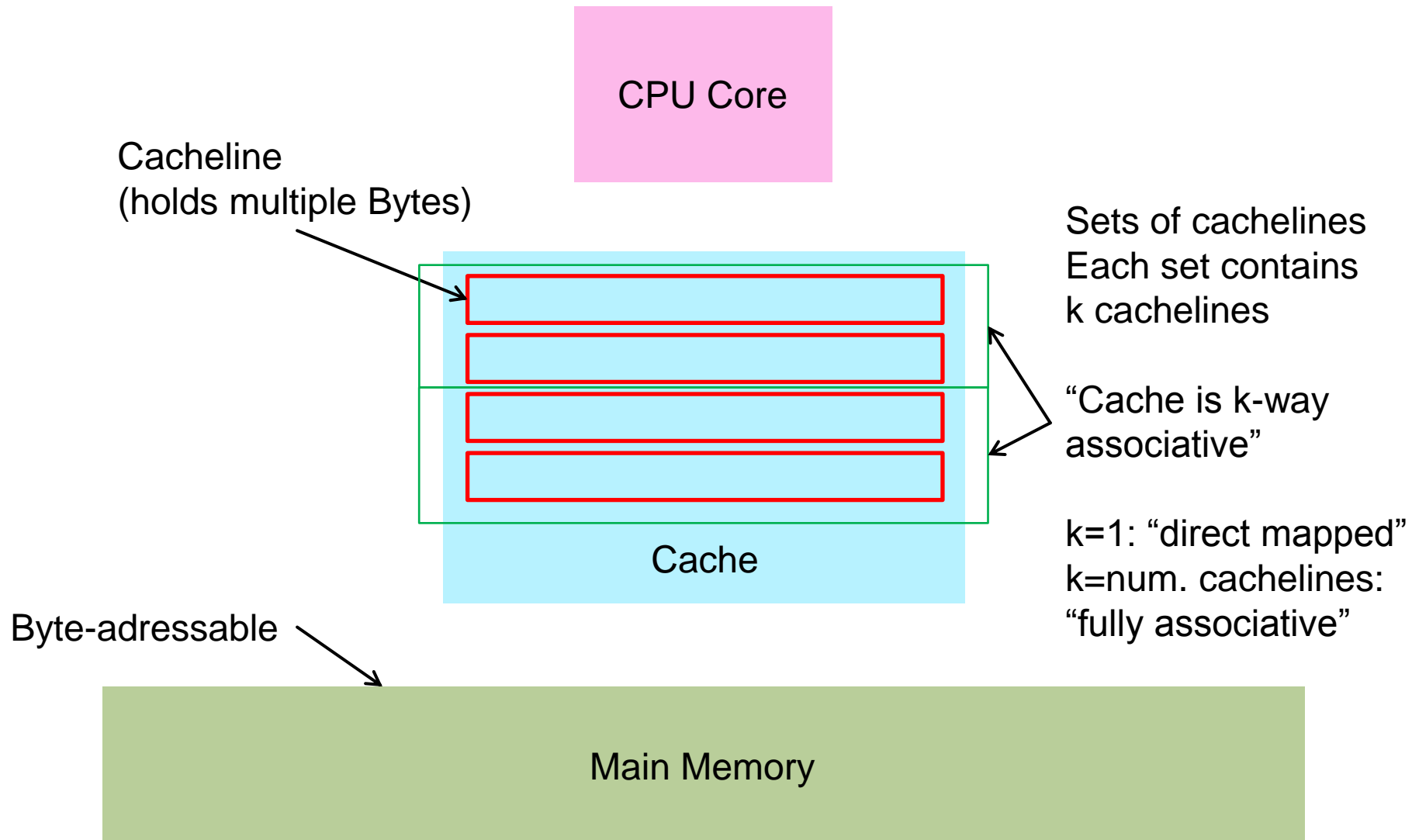

Cache Organization – Lookup Procedure

- **How do we check if a memory address X is cached?**
 - Each address can go into exactly one set
 - Split address into three parts: Tag, Set, Offset
 - Use the set part to locate the correct set
 - Compare the tag to all stored tags which are “valid”

Quiz

- **Explain the term**
 - Cache coherence
 - Multi-level cache
 - Shared Cache
 - Write back / write through cache
 - Victim cache

Cache coherence

- Assume we have two cores, each with its own cache
- Both load a shared variable $X=0$
- Now core0 writes to $X=1$
- What happens if core1 uses/reads X now?

- What actually happens depends on the cache implementation, i.e., if we have a write back or write through cache
- But what we want (cache coherence) is:
 - Updates are visible to all readers (Write propagation)
 - Writes to the same location appear in order (Write serialization)

Cache Coherence Protocols - MESI

- **Each cacheline is in one of four states**
- **Modified**
 - The copy in this cache is the only one
 - And the copy in this cache is newer than memory
- **Exclusive**
 - Our cache is the only one which has this cacheline
 - And Memory is up to date
- **Shared**
 - Other copies might exist
 - And memory is up to date
- **Invalid**
 - Cacheline is invalid

Quiz – MESI Protocol

- **What are the events that affect the state of a cache line?**
 - Local Read, Local Write, Read Request on Bus, Shared Signal on Bus, ReadExclusive Request on the Bus
- **What happens if a CL is in state M and the local core reads it?**
 - It stays in state M
- **What happens if a CL is in state I and the local core reads it?**
 - It goes to state E or S, depending how the other caches respond to the Read Request
- **What happens if a CL is in state I and the local core writes to it**
 - ReadExclusive is used to make sure others invalidate their copy and we can go to state M
- **What happens if a CL is in state M and changes its state?**
 - This happens as a result of a read request, so the CL has to be written to memory first
- **Explain a possible optimization of the MESI protocol**
 - MOESI, allows cache to cache data transfer of modified cache lines

Homework

- Available on course website
- Idea: Solve it **after** the recitation session
- We discuss the solution briefly next recitation session, good idea to bring your solution to compare and ask questions in case you got different results.